



WEDO | 维度®

维 匠 心 之 工 艺 度 劳 者 之 安 康

WEDO | 维度®



匠
维度只为 
 WE THE CRAFTSMEN DO SAFETY FIRST

2021

CCTV 荣誉热播



全国免费服务热线
 400-0022-737
 www.wedotools.com

PROFESSIONAL TOOLS

维度工具 德国品质 匠心智造 传承经典

德国总部:
 ADD: Ludwig-Richter-Str. 6, D-42329 Wuppertal, DEUTSCHLAND
 TEL: 0049-202-29572854 / 0049-202-44895980
 FAX: 0049-202-44895982
 E-MAIL: info@wedotools.com

中国上海部:
 地址: 上海市虹口区宝山路778号
 电话: +86-21-66291895 / +86-21-66291756
 手机: 139 1858 3773 / 166 2117 3522
 邮箱: sales5@wedotools.com

中国天津部:
 地址: 天津市南开区南泥湾路熙汇商务中心C座603
 电话: +86-22-27339156 / +86-22-27339157
 手机: 158 2233 1858 / 158 2267 1714
 邮箱: sales3@wedotools.com

2021.06

公司简介 INTRODUCTION

维度工具是集五金工具设计研发、制造加工、市场营销为一体的国际化专业企业。产品经过大型压力机一次性模锻而成，完全符合德国DIN标准、美国ASME标准或中国GB标准。我们以科学的管理体制，超前、独特的设计理念，先进的生产工艺以及完善的质量保证体系，为用户提供更高品质的产品与服务。公司凭借“以人为本”的设计理念、对卓越质量的孜孜以求及售后服务的不断完善，赢得新老客户对“维度”品牌工具的盛赞。

维度产品覆盖防爆工具、不锈钢工具、钛合金工具、绝缘工具、特种钢制工具及普通钢制工具六大系列。维度工具不仅在德国、中国生产销售，同时远销美国、俄罗斯、日本、法国、等100多个国家和地区。为提升客户满意度，公司相继在天津、上海、韩国、俄罗斯、德国、新加坡、加拿大设有服务中心，确保为终端客户提供实用型的安全创新工具和及时的售后服务。

维度愿与全世界人民一起分享工具的乐趣。

WEDO TOOLS CO., LTD, as an international professional enterprise, specializes in design, research, manufacturing, processing and marketing of hardware tools. Our products are one-time die-forged by large friction pressing machines, completely in accordance with Germany DIN standard and China GB standards. Based on a scientific management system, state-of-art and unique design concepts, advanced production technology and a well-developed quality assurance system, we provides high-quality products and services for our customers. WEDO TOOLS has been highly praised by our new and old customers because of our user-friendly design concept, continuous improvement of excellent quality and after-sales services.

WEDO TOOLS develops six series of products, including non-sparking tools, stainless steel tools, titanium tools, insulated tools, special jumbo tools and ordinary steel tools. We not only produce and sell tools in Germany and China, but also export to more than 100 countries and regions all over the world, such as the USA, Russia, Japan, France, etc. In order to further improve customers' satisfaction, WEDO has established service centers in Tianjin, Shanghai, Korea, Russia, Germany, Singapore and Canada, supplying safe and innovative hand tools and in-time after-sale services to end users.

We sincerely invite people all over the world to share the pleasure of tools.



[维度展厅/WEDO showroom]

[国际展会/International Exhibitions]

[精锻车间/Precision Forging Workshop]

[成品仓库/Finished Products Warehouse]



全国五金制品标准化技术委员会工具五金分技术委员会
全国工具五金标准化中心

TC174/SC2

证书

CERTIFICATE

证明

杨景维

为以下工具五金标准的起草人

GB/T 10686-2013

铜合金工具防爆性能试验方法



全国五金制品标准化技术委员会工具五金分技术委员会
全国工具五金标准化中心

TC174/SC2

证书

CERTIFICATE

证明

杨景维

为以下工具五金标准的起草人

QB/T 2613.11-2015 防爆工具 防爆用十字槽螺钉旋具

QB/T 2613.12-2015 防爆工具 防爆用一字槽螺钉旋具

QB/T 2613.13-2015 防爆工具 防爆用钢丝钳

QB/T 2613.14-2015 防爆工具 防爆用两用扳手





Certificate

N°: BAM/ZBF/003/17



Hereby it is confirmed by the BAM Certification Body, that the

Material "Beryllium-copper alloy"

of the manufacturer

WEDO TOOLS GmbH
Ludwig-Richter-Straße 6
42329 Wuppertal
Deutschland

meets the requirements of BAM Standard operating procedure „StAA-NEG-005“:
„StAA zur Schlagfunkenprüfung von Werkstoffpaarungen“ dated 2017-03-01
and thus the non-sparking tools made of this material are appropriate for use in
potentially explosive atmospheres of zone 1 and/or 21 according to Directive
1999/92/EC of all explosion groups (I, IIA, IIB & IIC) according to IEC 60079-20-1
(2010), if the terms and conditions set out in the annex to this certificate are met.

The certification is based on certification contract N° **BAM-ZBF-0003-2017-WEDO TOOLS** and comprises according to standard ISO/IEC 17065:2012 a design-type test with the manufacturer's declaration of conformity (BAM Certification system I). The products certified by BAM may be labelled with the certification mark "BAM design-type tested" / "BAM Baumustergeprüft".

The certificate is valid until November 16th, 2022.

BAM test report 17043458 dated 2017-11-06 as well as procedure N° BZS-GS/033/17 form the basis of this certificate.

For Bundesanstalt für Materialforschung und -prüfung (BAM)
Unter den Eichen 87,12205 Berlin, 2017-11-17



Dr. R. Schmidt
BAM Certification Body





Dr. R. Grätz
BAM Assessor

Distribution list: 1st Certificate holder 2nd BAM Certification Body

This certificate may only be published in full wording and without any additions. A revocable written consent shall be obtained from BAM beforehand for any amended reproduction or the publication of any excerpts. The German version is legally binding, except an English version is issued exclusively. Place of jurisdiction is Berlin.

Sicherheit in Technik und Chemie

CERTIFICATE



Registered / Enregistré 26/07/2016

No 011423019

EUROPEAN UNION INTELLECTUAL PROPERTY OFFICE
CERTIFICATE OF REGISTRATION

This Certificate of Registration is hereby issued for the European Union trade mark identified below. The corresponding entries have been recorded in the Register of European Union trade marks.

OFFICE DE L'UNION EUROPÉENNE POUR LA PROPRIÉTÉ INTELLECTUELLE
CERTIFICAT D'ENREGISTREMENT

Le présent Certificat d'Enregistrement est délivré pour la marque de l'Union européenne identifiée ci-joint. Les mentions et les renseignements qui s'y rapportent ont été inscrits au Registre des Marques de l'Union Européenne.



The Executive Director / Le Directeur exécutif



António Campinos

中国新闻出版社天津出版中心 (集团)

编号: JX0862017



老故事《匠心》栏目

展播企业

维度防爆工具(天津)集团有限公司

老故事《匠心》栏目
2017年11月12日至2018年

United States of America
United States Patent and Trademark Office



Reg. No. 5,224,243

Registered Jun. 13, 2017

Int. Cl.: 8

Trademark

Principal Register

WEDO TOOLS CO., LTD. (CHINA limited company (Ltd.))
3-17-603 HARDWARE ZONE MIYUN YIZHI ROAD
NANKAI DIST., TIANJIN CHINA

CLASS 8: Hand operated abrading tools; Hand-operated riveting tools; Pickhammers; Spades; Hand-operated agricultural implements, namely, broadforks; Lawn and garden tools, namely, cultivators; Hand tools, namely, wrenches; Hand-operated hammers; Screwdrivers; Pliers; Hand-operated cutting tools; Hand operated lifting jacks; Hand tools, namely, ratchet wrenches; Hand tools, namely, spatulas; Tweezers; Hand tools, namely, scrapers

FIRST USE 10-1-2016; IN COMMERCE 10-1-2016

The mark consists of a stylized image containing various intersecting lines and shapes; the word "WEDO" appears to the right in stylized letters in stylized font with a triangle appearing under the letter "W" in the mark. To the left of the wording is a stylized image comprised of a letter "V" with three straight and three bent rectangles forming a semi-circle and base.

SER. NO. 86-949,234, FILED 03-22-2016
SAIMA MAKHDOOM, EXAMINING ATTORNEY



Joseph Matol

Performing the Functions and Duties of the
Under Secretary of Commerce for
Intellectual Property and Director of the
United States Patent and Trademark Office



商標登録証
(CERTIFICATE OF TRADEMARK REGISTRATION)

登録第 6161267 号
(REGISTRATION NUMBER)

商標
(THE MARK)



指定商品又は指定役務並びに商品及び役務の区分
(LIST OF GOODS AND SERVICES)

第 8 類 研磨用具 (手持工具に当たるものに限る。)、びしゃん、手動式農業用器具、園芸用器具 (手動式のもの) その他別紙記載

商標権者
(OWNER OF THE TRADEMARK RIGHT) 中華人民共和国天津市南開区南泥湾路与延安路交口北方城三区 17-603
国籍・地域 中華人民共和国
天津维度防爆工具有限公司

出願番号
(APPLICATION NUMBER) 商願 2018-119462
出願日
(FILING DATE) 平成 30 年 9 月 20 日 (September 20, 2018)
登録日
(REGISTRATION DATE) 令和 1 年 7 月 12 日 (July 12, 2019)

この商標は、登録するものと確定し、商標原簿に登録されたことを証する。
(THIS IS TO CERTIFY THAT THE TRADEMARK IS REGISTERED ON THE REGISTER OF THE JAPAN PATENT OFFICE.)

令和 1 年 7 月 12 日 (July 12, 2019)

特許庁長官
(COMMISSIONER, JAPAN PATENT OFFICE)

松永



证书号第 10033251 号



实用新型专利证书

实用新型名称: 一种具有调节功能的活动扳手

发明人: 杨景维

专利号: ZL 2019 2 0749955.5

专利申请日: 2019年05月23日

专利权人: 天津维度防爆工具有限公司

地址: 300000 天津市南开区南泥湾路与延安路交口北方城三区 1 7-603

授权公告日: 2020年02月11日 授权公告号: CN 210046582 U

国家知识产权局依照中华人民共和国专利法经过初步审查, 决定授予专利权, 颁发实用新型专利证书并在专利登记簿上予以登记。专利权自授权公告之日起生效。专利权期限为十年, 自申请日起算。

专利证书记载专利权登记时的法律状况。专利权的转移、质押、无效、终止、恢复和专利权人的姓名或名称、国籍、地址变更等事项记载在专利登记簿上。



2020年02月11日

第 1 页 (共 2 页)

实用新型专利证书

实用新型名称: 一种...
发明人: ...
专利号: ...
专利申请日: ...
专利权人: ...



实用新型专利证书

实用新型名称: 一种...
发明人: ...
专利号: ...
专利申请日: ...
专利权人: ...



实用新型专利证书

实用新型名称: 一种...
发明人: ...
专利号: ...
专利申请日: ...
专利权人: ...



外观设计专利证书

外观设计名称: ...
设计人: ...
专利号: ...
申请日: ...
专利权人: ...



外观设计专利证书

外观设计名称: ...
设计人: ...
专利号: ...
申请日: ...
专利权人: ...



外观设计专利证书

外观设计名称: ...
设计人: ...
专利号: ...
申请日: ...
专利权人: ...



01-109

WEDO | 维度® 防爆工具系列 *NON-SPARKING TOOLS SERIES*



110-117

WEDO | 维度® 黄铜、紫铜工具系列 *BRASS AND COPPER TOOLS*



119-147

WEDO | 维度® 绝缘工具系列 *INSULATED TOOLS SERIES*



149-164

WEDO | 维度® 特种钢制工具系列 *SPECIAL JUMBO TOOLS SERIES*



165-211

WEDO | 维度® 钢制工具系列 *STEEL TOOLS SERIES*



213-235

WEDO | 维度® 不锈钢工具系列 *STAINLESS STEEL TOOLS SERIES*



237-250

WEDO | 维度® 钛合金工具系列 *TITANIUM TOOLS SERIES*



铝青铜防爆工具

产品货号AL为首

- 铝青铜防爆性能
 1. 适用于浓度7.8%以下的乙烯气体中作业；
 2. 标准代号GBEx II B、硬度HRC20-30、抗拉强度 δ_0 75-85kgf/mm²；
 3. 采用4.0工艺模锻，德国DIN标准、密度高、韧性好、使用寿命长；
- 适用范围

适用于石油精炼和石油化学工业、煤矿、油田、天然气化学工业、火药工业、化纤工业、油漆工业、肥料工业、各种药品工业及易燃易爆场进行作业时，冲撞击、摩擦、落锤均不产生火花爆炸；

铍青铜防爆工具

产品货号BE为首

- 铍青铜防爆性能
 1. 适用于浓度21%以下的氢气中作业；
 2. 标准代号GBEx II C、硬度HRC30-40、抗拉强度 δ_0 105-120kgf/mm²；
 3. 采用4.0工艺模锻，德国DIN标准、密度高、韧性好、使用寿命长，具有防磁性能；
- 适用范围

适用于石油精炼和石油化学工业、煤矿、油田、天然气化学工业、火药工业、化纤工业、油漆工业、肥料工业、各种药品工业及易燃易爆场进行作业时，冲撞击、摩擦、落锤均不产生火花爆炸；

维度防爆工具

WEDO NON-SPARKING TOOLS / ATEX=防爆

爆炸危险区域划分 / Classification of Zones by Explosion Risks

可行性	高危险区 0区	一般危险区 1区	低危险区 2区
气、油、雾或蒸汽	指的是空气和易燃物频繁、持续或长时间以气、雾、蒸汽形式混合存在的危险环境。	指的是空气和易燃物在正常操作下可能偶尔以气、雾、蒸汽形式混合存在的危险环境。	指的是空气和易燃物在正常操作不大可能以气、雾、蒸汽形式混合存在的危险环境，或者即使存在，也只是非常短的时间。
粉尘	20区 指的是空气中的可燃粉尘频繁持续或长时间存在的危险环境。	21区 指的是空气中的可燃粉尘在正常操作下可能偶尔存在的危险环境。	22区 指的是空气中的可燃粉尘在正常操作下不大可能存在的危险环境，或者即使存在，也只是非常短的时间。

矿1	如果发生瓦斯泄漏事故，操作还有可能继续
矿2	如果发生瓦斯泄漏事故，操作必须停止

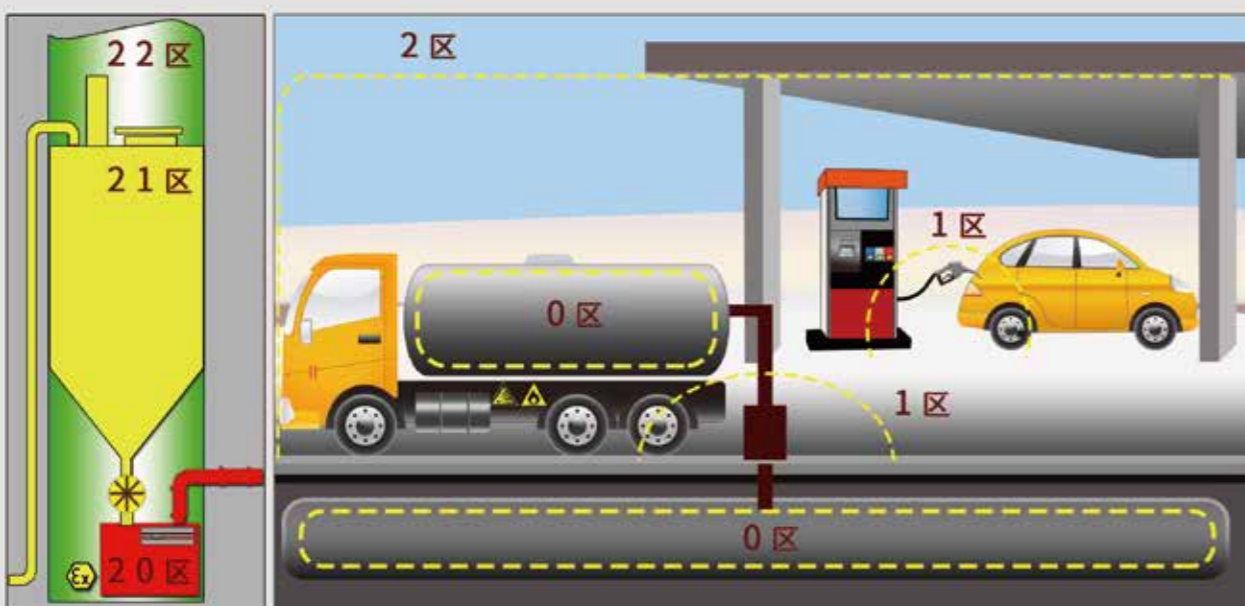

铍青铜合金和铝青铜合金的属性对比:

铍青铜合金 (Be-Cu)	
铍	1.5-1.7% 1.8-2.3%
钴+镍	0.2%以上
钴+镍+铁	1.2%以下
铜+铍+钴+镍+铁	99.0%以上
洛氏硬度	30-40HRC
抗拉强度	1117N/mm ² -1326N/mm ²
延展率	δ≤1.0%
弹性限度	840N/mm ² -880N/mm ²
磁性	0
铝青铜合金 (Al-Br)	
铝	10-12%
镍	4-6%
铁+锰	5.8%以下
铜+铝+镍+铁+锰	99.0%以上
洛氏硬度	20-30HRC
抗拉强度	782N/mm ² -989N/mm ²
延展率	δ≥5%
弹性限度	450N/mm ² -550N/mm ²
磁性	1.2

性能和应用:

防爆	适用于易爆场所，如石油、燃气、化工厂等，能有效防止操作过程产生火花。
无磁	对于要求完全无磁的设备是必不可少的。
耐腐蚀	特别适用于腐蚀性环境，如海事或消防作业。
模锻	提供更高的机械性能和更好的表面处理效果。

防爆工具的应用领域:

石油	化工	矿业
炼油厂	烟花产业	国防
燃气和石油管道	面粉厂	空军
发电厂	酿酒厂	海军
油漆制造	酒精加工	武器弹药生产
塑料制造	蒸馏	航空业
制药业	消防作业	汽车产业

工业级安全箱

1 锁扣耐冲击设计，任何情况都开启自如。

2 通过防水测试，能有效防止水、粉尘进入。

3 高韧性及抗变形能力，适用于任何运输环境

4 自动防水透气阀，自动调节箱内压力，所以在任何环境下轻松自如打开安全箱，而且保证安全箱内部的干燥

5 独特结构设计，更坚固，轻便。

6 强化的软包拉手，使用舒适，适合长时间负重使用。

7 特有堆叠时防滑设计

- 超强的抗冲击及耐低温性能，卓越的韧性及抗变形能力，适用任何极端运输环境，耐-55℃超低温。
- 广泛应用于广电摄影、工业仪器、国防军事、警用执法、IT、户外活动等领域，产品应用包括精密仪器防护箱、野外摄影摄像保护箱、检测工具配套箱、潜水设备防护箱，以及运输周转箱、枪械箱、抗震机架箱、空投箱、野战办公桌等。
- 卓越的细节设计及理念，齐全的配件供应，充分考虑各行业的广泛要求。
- 密封防水、防尘、自动调节内外压力，客户产品得到最精细的保护。

防爆1/4" 方10件套盒装套筒

1/4" Dr Socket Set-10pcs

- AL-BR:690g
- BE-CU:710g
- 铍青铜/铝青铜材质，使用安全无火花。Beryllium copper/aluminium bronze material, non-sparking safely to be used.
- 一次性模锻而成，硬度高，扭力强且使用省力。One-time die-forged, high hardness, strong torque and labor saving
- 符合德国DIN标准以及中国GB标准。Accordance with Germany DIN standard and China GB standard.

货号		规格	
铝青铜合金	铍青铜合金	(mm)	
AL101A	BE101A	套筒 1/4"	Socket (4,4.5,5,5.5,6,7,8)mm
		旋具手柄 1/4"	Driver Type Handle
		短柄一字螺丝刀	Stubby Slotted Screwdriver
		短柄十字螺丝刀	Stubby Phillips Screwdriver

防爆1/4" 方11件套盒装套筒

1/4" Dr Socket Set-11pcs

- AL-BR:720g
- BE-CU:740g
- 铍青铜/铝青铜材质，使用安全无火花。Beryllium copper/aluminium bronze material, non-sparking safely to be used.
- 一次性模锻而成，硬度高，扭力强且使用省力。One-time die-forged, high hardness, strong torque and labor saving
- 符合德国DIN标准以及中国GB标准。Accordance with Germany DIN standard and China GB standard.

货号		规格	
铝青铜合金	铍青铜合金	(mm)	
AL101B	BE101B	套筒 1/4"	Socket (4,5,6,7,8,9,10,11,12,13)mm
		旋具手柄 1/4"	Driver Type Handle

防爆3/8" 方13件套盒装套筒

3/8" Dr Socket Set-13pcs

- AL-BR:1650g
- BE-CU:1740g
- 铍青铜/铝青铜材质，使用安全无火花。Beryllium copper/aluminium bronze material, non-sparking safely to be used.
- 一次性模锻而成，硬度高，扭力强且使用省力。One-time die-forged, high hardness, strong torque and labor saving
- 符合德国DIN标准以及中国GB标准。Accordance with Germany DIN standard and China GB standard.

货号		规格	
铝青铜合金	铍青铜合金	(mm)	
AL101C	BE101C	套筒 3/8"	Socket (8,9,10,11,12,13,14,17,19)mm
		火花塞	13/16" Spark plug Socket
		棘轮扳手	Ratchet Wrench 3/8" *200mm
		直接头	Straight Joint
		套筒接杆	Driver Extension 3/8" *75mm

防爆1/4" * 3/8" 方21件套盒装套筒

1/4" * 3/8" Dr Socket Set-21pcs

- AL-BR:2000g
- BE-CU:2130g
- 铍青铜/铝青铜材质，使用安全无火花。Beryllium copper/aluminium bronze material, non-sparking safely to be used.
- 一次性模锻而成，硬度高，扭力强且使用省力。One-time die-forged, high hardness, strong torque and labor saving
- 符合德国DIN标准以及中国GB标准。Accordance with Germany DIN standard and China GB standard.

货号		规格	
铝青铜合金	铍青铜合金	(mm)	
AL101D	BE101D	套筒 1/4"	Socket (4,4.5,5,5.5,6,7,8)mm
		换向棘轮扳手	Ratchet Wrench 3/8" *200mm
		直接头	Straight Joint
		套筒连接杆	Driver Extension 75mm,150mm
		套筒 3/8"	Socket (10,11,12,13,14,17,19)mm
		火花塞套筒	13/16" Spark Plug Socket
		变径接头	Adaptor 3/8" *1/4"
		旋具手柄	Driver Type Handle 1/4" *55mm



防爆1/2" 方9件套盒装套筒

1/2" Dr Socket Set-9pcs

- AL-BR:1890g
- BE-CU:2000g
- 铍青铜/铝青铜材质，使用安全无火花。Beryllium copper/aluminium bronze material, non-sparking safely to be used.
- 一次性模锻而成，硬度高，扭力强且使用省力。One-time die-forged, high hardness, strong torque and labor saving
- 符合德国DIN标准以及中国GB标准。Accordance with Germany DIN standard and China GB standard.

货号		规格	
铝青铜合金	铍青铜合金	(mm)	
AL101E	BE101E	套筒 1/2"	Socket (10,11,12,14,17,19,22,24)mm
		套筒弯柄	Offset Handle 1/2" *230mm

防爆套筒连接杆
Driver Extension

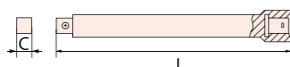

- 配套筒头和手柄使用, 松紧深凹处的六角螺栓、螺母。
Used with socket and handle, to loosen or tighten hexagon bolts and nuts in narrow or deep recessed space.
- 铍青铜/铝青铜材质, 使用安全无火花。
Beryllium copper/aluminum bronze material, non-sparking safely to be used.
- 符合德国DIN3123标准。
Accordance with Germany DIN3123 standard.

货号		规格		重量(g)	
铝青铜合金	铍青铜合金	C(inch)	L(mm)	铝青铜合金	铍青铜合金
AL122-1002	BE122-1002	3/8	75	80	93
AL122-1004	BE122-1004	3/8	150	160	185
AL122-1006	BE122-1006	1/2	100	225	245
AL122-1008	BE122-1008	1/2	125	230	260
AL122-1010	BE122-1010	1/2	200	330	365
AL122-1012	BE122-1012	1/2	250	425	470
AL122-1014	BE122-1014	3/4	200	770	855
AL122-1016	BE122-1016	1	200	1380	1525

防爆L型双头套筒扳手
Wrench, Socket L-Type

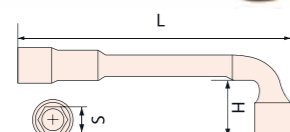

- 适用于长螺栓螺母, 深孔螺栓螺母的紧固。
Used for fastening long bolt and deep-hole bolt.

货号		规格			重量(g)	
铝青铜合金	铍青铜合金	S(mm)	L(mm)	H(mm)	铝青铜合金	铍青铜合金
AL122A-6	BE122A-6	6	102	18	40	45
AL122A-7	BE122A-7	7	106	18	45	50
AL122A-8	BE122A-8	8	114	22	65	72
AL122A-9	BE122A-9	9	122	22	80	90
AL122A-10	BE122A-10	10	129	25	120	130
AL122A-11	BE122A-11	11	136	25	125	140
AL122A-12	BE122A-12	12	144	28	150	165
AL122A-13	BE122A-13	13	152	30	185	200
AL122A-14	BE122A-14	14	160	32	195	215
AL122A-15	BE122A-15	15	169	35	240	265
AL122A-16	BE122A-16	16	178	35	295	325
AL122A-17	BE122A-17	17	187	40	315	350
AL122A-18	BE122A-18	18	195	40	345	380
AL122A-19	BE122A-19	19	204	45	440	485
AL122A-21	BE122A-21	21	221	50	525	580
AL122A-22	BE122A-22	22	230	50	590	650
AL122A-24	BE122A-24	24	250	55	640	705
AL122A-27	BE122A-27	27	280	65	1030	1135
AL122A-30	BE122A-30	30	310	70	1300	1460
AL122A-32	BE122A-32	32	330	75	1570	1730
AL122A-34	BE122A-34	34	350	75	1600	1760
AL122A-36	BE122A-36	36	370	80	1670	1840

防爆快速摇柄
Speed Handle

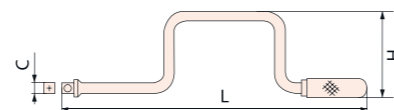

- 在狭窄的空间中用来代替棘轮, 曲柄形手柄可快速连续旋转节省大量时间和精力。
Used to replace ratchet in narrow place. The handle can rotate fast and continuously for saving time and labor greatly.

货号		规格			重量(g)	
铝青铜合金	铍青铜合金	C(inch)	L(mm)	H(mm)	铝青铜合金	铍青铜合金
AL123-1002	BE123-1002	1/2	390	96	700	780

防爆旋具手柄
Driver Type Handle



- 与1/4"套筒直接配合使用。
Used with 1/4" socket.
- 铍青铜/铝青铜材质, 使用安全无火花。
Beryllium copper/aluminum bronze material, non-sparking safely to be used.
- 符合德国DIN3122标准。
Accordance with Germany DIN3122 standard.

货号		规格			重量(g)	
铝青铜合金	铍青铜合金	C(inch)	L(mm)	H(mm)	铝青铜合金	铍青铜合金
AL124-1002	BE124-1002	1/4	170	55	85	95

防爆省力扳手
Labor Saving Wrench



- 适用于拆装汽车轮胎使用, 采用高速行星变速机构, 可轻松操作。
Disassemble or assemble automobile tires with high speed planetary gear transmission mechanisms, operate efficiently.
- 一次性模锻而成, 硬度高, 使用省力。
Onetime die forged, high hardness and labor saving.

货号		规格		重量(g)	
铝青铜合金	铍青铜合金	规格	规格	铝青铜合金	铍青铜合金
AL124A-1002	BE124A-1002	ZB-16		1800	2000
AL124A-1004	BE124A-1004	ZB-58		6200	6850
AL124A-1006	BE124A-1006	ZB-68		7300	8050
AL124A-1008	BE124A-1008	ZB-78		7500	8300



高品质原材料
防爆工具采用贵重稀有的有色金属科学配比而成, 分为铍青铜工具和铝青铜工具, 铍青铜工具表面呈金黄色, 铝青铜工具表面呈银黄色。

High Quality Raw Materials
Non-sparking tools are made of expensive and rare non-ferrous metal in good proportion(Be-Cu & Al-Br). The final products are in golden or silver yellow.

先进的模锻工艺
采用大型摩擦压力机一次性模锻而成, 硬度高, 扭力强, 完全符合德国 DIN 标准, 使用省力, 寿命提高 30%。

Advanced Die-forged Process
One-time die-forged, high hardness, strong torque, completely in accordance with Germany DIN standard. Low physical effort and increasing 30% lifespan.



维度工业级防爆工具, 专业保障工业生产安全

专业 - 安全

维度防爆工具工艺流程
Technical process of WEDO non-sparking tools



扳手的使用注意事项
Instruction of Wrench

1. 使用正确尺寸的扳手。
Use the just size wrench.
2. 切勿将扳手当做杠杆使用。
Do not use the wrench as a lever.
3. 切勿随意加延长杆操作, 除非此工具有这样的设计功能。
Do not use with extension bar at random, unless this tool has such designed function.
4. 切勿用锤子敲击扳手, 除非此工具有这样的设计功能, 如: 敲击扳手。
Do not strike wrench with a hammer, unless this tool has such designed function, such as striking wrench.
5. 将扳手放置到正确的工位时才开始施力。
Exert a force on wrench when the wrench is placed in the correct station.
6. 梅花扳手传递扭力更流畅, 故更适用于大扭矩。
Box wrench transmits torque more smoothly, so it is more suitable for high torque.
7. 损坏的扳手不应再投入使用, 切勿自行修理扳手。
Damaged wrench should not be used again. Do not repair damaged wrench.

防爆活扳手
Wrench, Adjustable

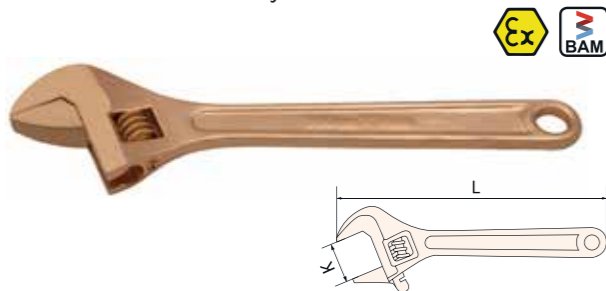

- 开口宽度可以调节,可用于拆装六角头或方螺栓、螺母。
Adjustable opening size, suitable for different sizes of fasteners.

货号		规格		重量(g)	
铝青铜合金	铍青铜合金	L(mm)	Kmax(mm)	铝青铜合金	铍青铜合金
AL125-1002	BE125-1002	100	13	30	33
AL125-1004	BE125-1004	150	18	130	145
AL125-1006	BE125-1006	200	24	240	275
AL125-1008	BE125-1008	250	30	435	485
AL125-1010	BE125-1010	300	36	715	780
AL125-1012	BE125-1012	375	46	1415	1545
AL125-1014	BE125-1014	450	55	2120	2360
AL125-1016	BE125-1016	600	65	4300	4700

防爆活扳手
Wrench, Adjustable, Plastic Handle



- 铍青铜/铝青铜材质,使用安全无火花。
Beryllium copper/aluminum bronze non-sparking safely to be used

货号		规格		重量(g)	
铝青铜合金	铍青铜合金	L(mm)	Kmax(mm)	铝青铜合金	铍青铜合金
AL125A-1002	BE125A-1002	100	13	30	33
AL125A-1004	BE125A-1004	150	18	130	145
AL125A-1006	BE125A-1006	200	24	240	275
AL125A-1008	BE125A-1008	250	30	465	485
AL125A-1010	BE125A-1010	300	36	715	780
AL125A-1012	BE125A-1012	375	46	1220	1400
AL125A-1014	BE125A-1014	450	55	1900	2150
AL125A-1016	BE125A-1016	600	65	3100	3500

防爆塑柄活扳手
Wrench, Adjustable



- 铍青铜/铝青铜材质,使用安全无火花。
Beryllium copper/aluminum bronze material, non-sparking safely to be used.

货号		规格		重量(g)	
铝青铜合金	铍青铜合金	L(mm)	Kmax(mm)	铝青铜合金	铍青铜合金
AL125D-1002	BE125D-1002	150	18	145	165
AL125D-1004	BE125D-1004	200	24	270	300
AL125D-1006	BE125D-1006	250	30	500	550
AL125D-1008	BE125D-1008	300	36	680	750

防爆平把多用活扳手
Wrench, Adjustable

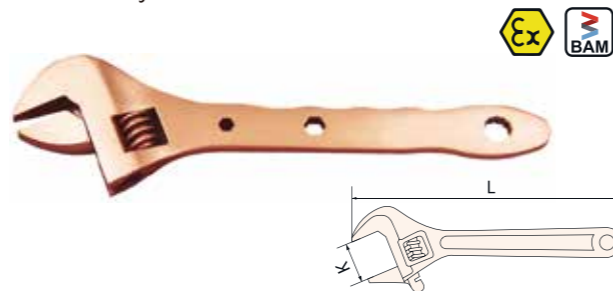

- 铍青铜/铝青铜材质,使用安全无火花。
Beryllium copper/aluminum bronze material, non-sparking safely to be used.

货号		规格		重量(g)	
铝青铜合金	铍青铜合金	L(mm)	Kmax(mm)	铝青铜合金	铍青铜合金
AL125E-1002	BE125E-1002	150	18	150	175
AL125E-1004	BE125E-1004	200	24	250	290
AL125E-1006	BE125E-1006	250	30	420	485
AL125E-1008	BE125E-1008	300	36	650	750

防爆三用活扳手
Wrench, Adjustable



- 在活扳手正常使用的基础上增加了夹持圆形零件和敲击作用。
Based on the normal use of adjustable wrenches, increase the function of clamping round parts and hammering.

货号		规格			重量(g)	
铝青铜合金	铍青铜合金	L(mm)	Kmax(mm)	H(mm)	铝青铜合金	铍青铜合金
AL126-1002	BE126-1002	350	36	80	1251	1384

防爆猴式活扳手
Wrench, Monkey

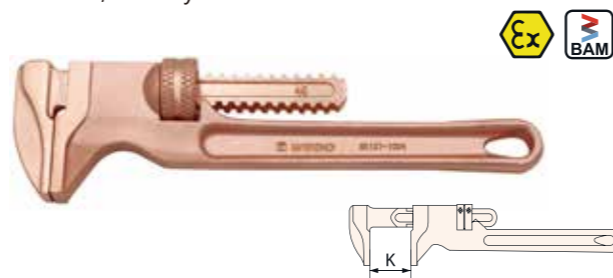

- 调节范围大,可以同时适用于更多规格的六角螺栓、螺母。
Wide adjustable range, suitable for more different sizes of fasteners.

货号		规格		重量(g)	
铝青铜合金	铍青铜合金	L(mm)	Kmax(mm)	铝青铜合金	铍青铜合金
AL127-1002	BE127-1002	240	45	470	510
AL127-1004	BE127-1004	254	48	560	615
AL127-1006	BE127-1006	305	58	820	910
AL127-1008	BE127-1008	350	65	1120	1220
AL127-1010	BE127-1010	380	70	1340	1465

防爆汽车扳手
Motor Wrench

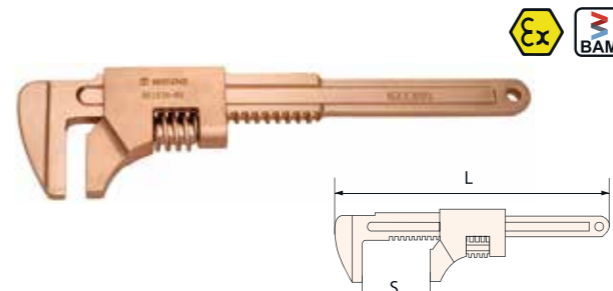

- 坚固、调节范围大,适用于易燃易爆场所重负荷工作。
Strong, wide adjustable range, used for heavy duty work in combustible and explosive area.
- 一次性模锻而成,硬度高,使用省力。
One-time die-forged, high hardness and labor saving.

货号		规格		重量(g)	
铝青铜合金	铍青铜合金	L(mm)	S(mm)	铝青铜合金	铍青铜合金
AL127A-62	BE127A-62	250	62	520	575
AL127A-78	BE127A-78	280	78	780	860
AL127A-82	BE127A-82	375	82	1300	1430

防爆45°瑞典水泵钳
Wrench, Swedish Type 45°

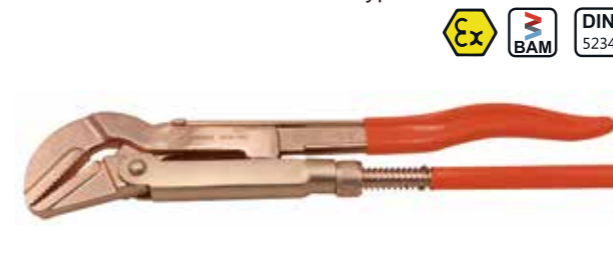

- 用于拆卸和紧固管子、管件和螺母。
Used for dismantling and fastening pipe, fittings nuts, etc.

货号		规格		重量(g)	
铝青铜合金	铍青铜合金	L(mm)	Kmax(mm)	铝青铜合金	铍青铜合金
AL128-1002	BE128-1002	430	38	1400	1550
AL128-1004	BE128-1004	530	50	2000	2230

防爆瑞典式S型管钳
Wrench, Swedish Type

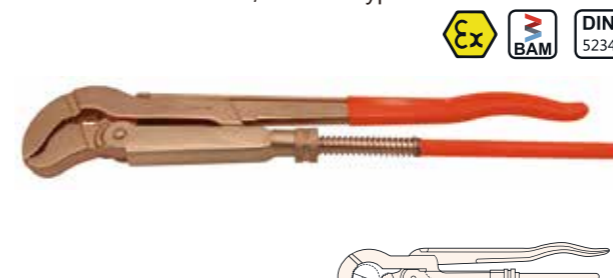

- 钳口可防止工件的滑落,确保有限空间内的最大移动自由度。
The jaw prevents the workpiece from sliding off, maximum the degree of movement in a limited space.

货号		规格		重量(g)	
铝青铜合金	铍青铜合金	L(mm)	D(inch)	铝青铜合金	铍青铜合金
AL128A-1002	BE128A-1002	530	2	2355	2605
AL128A-1004	BE128A-1004	650	3	4060	4500
AL128A-1006	BE128A-1004	790	4	5600	6200

防爆90° 瑞典水泵钳
Wrench, Swedish Type 90°



- 用于拆卸和紧固管子、管件和螺母。
Used for dismantling and fastening pipe, fittings nuts, etc.

货号		规格		重量(g)	
铝青铜合金	铍青铜合金	L(mm)	Kmax(mm)	铝青铜合金	铍青铜合金
AL128B-1002	BE128B-1002	430	38	1330	1480

防爆链型管钳
Wrench, Chain Pipe

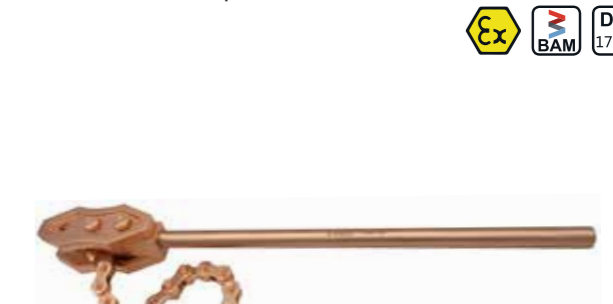

- 用于紧固和拆卸较大的金属管和圆柱形零件。
Used for dismantling and fastening big pipes and cylindrical fittings.

货号		规格		重量(g)	
铝青铜合金	铍青铜合金	L(mm)	Dmax(mm)	铝青铜合金	铍青铜合金
AL129-1002	BE129-1002	600	100	3605	3955
AL129-1004	BE129-1004	600	150	4200	4650
AL129-1006	BE129-1006	900	200	7800	8600
AL129-1008	BE129-1008	900	300	9000	9810

防爆轻型链钳
Wrench, Light Chain Pipe



● 用于夹持、装配和拆卸管件和轴类零件。轻便，可用于狭窄空间操作。
Used for clamping, assembling and fastening pipes and shaft parts. Lightweight, can be operated in narrow spaces.

货号		规格		重量(g)	
铝青铜合金	铍青铜合金	L(mm)	Dmax(mm)	铝青铜合金	铍青铜合金
AL129A-1002	BE129A-1002	600	100	1910	2105
AL129A-1004	BE129A-1004	1600	450	9500	10500
AL129A-1006	BE129A-1006	300	60	940	1030

防爆多用扳手
Universal Wrench



● 铍青铜/铝青铜材质，使用安全无火花。
Beryllium copper/aluminum bronze material, non-sparking safely to be used.

货号		规格		重量(g)	
铝青铜合金	铍青铜合金	L(mm)	D(mm)	铝青铜合金	铍青铜合金
AL129C-1002	BE129C-1002	250	10-30	780	870
AL129C-1004	BE129C-1004	450	30-60	2200	2450

防爆英式管钳子
Wrench, Pipe (British Type)



● 用于夹持、装配和拆卸管件和轴类零件。
Used for clamping, assembling and dismantling pipes and shaft parts.
● 一次性模锻而成，硬度高，使用省力。
One-time die-forged, high hardness and labor saving.
● 铍青铜/铝青铜材质，使用安全无火花。
Beryllium copper/aluminum bronze material, non-sparking safely to be used.

货号		规格		重量(g)	
铝青铜合金	铍青铜合金	L(mm)	Kmax(mm)	铝青铜合金	铍青铜合金
AL130B-1002	BE130B-1002	200	25	380	430
AL130B-1004	BE130B-1004	250	30	520	580
AL130B-1006	BE130B-1006	300	40	780	88
AL130B-1008	BE130B-1008	350	50	1080	1250
AL130B-1010	BE130B-1010	450	60	1660	1910
AL130B-1012	BE130B-1012	600	75	2710	3115

防爆美式管钳子
Wrench, Pipe (American Type)

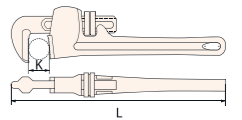

● 用于夹持、装配和拆卸管件和轴类零件。
Used for clamping, assembling and dismantling pipes and shaft parts.
● 一次性模锻而成，硬度高，使用省力。
One-time die-forged, high hardness and labor saving.
● 铍青铜/铝青铜材质，使用安全无火花。
Beryllium copper/aluminum bronze material, non-sparking safely to be used.

货号		规格		重量(g)	
铝青铜合金	铍青铜合金	L(mm)	Kmax(mm)	铝青铜合金	铍青铜合金
AL131-1002	BE131-1002	200	25	380	420
AL131-1004	BE131-1004	250	30	670	735
AL131-1006	BE131-1006	300	40	955	1050
AL131-1008	BE131-1008	350	50	1195	1315
AL131-1010	BE131-1010	450	60	2050	2255
AL131-1012	BE131-1012	600	75	3150	3465
AL131-1014	BE131-1014	900	85	5345	5880
AL131-1016	BE131-1016	1200	110	11450	12600

防爆皮带扳手
Wrench, Belt Pipe

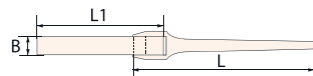

● 高强度尼龙带，用于装配和拆卸管件和轴类零件，轻便可用于狭窄空间，不伤害工件表面。
Strong Nylon Belt, used for dismantling and fastening pipes and shaft parts, no damages on surface of parts, lightweight, fit for narrow space.
● 铍青铜/铝青铜材质，使用安全无火花。
Beryllium copper/aluminum bronze material, non-sparking safely to be used.
● 精铸产品。
Precision Casting.

货号		规格			重量(g)	
铝青铜合金	铍青铜合金	L(mm)	L1(mm)	B(mm)	铝青铜合金	铍青铜合金
AL129B-1002	BE129B-1002	300	425	30	735	810

防爆管钳子
Wrench, Pipe

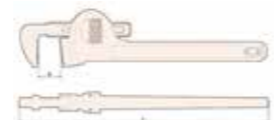

● 用于夹持、装配和拆卸管件和轴类零件。
Used for clamping, assembling and disassembling pipes and shaft parts.
● 铍青铜/铝青铜材质，使用安全无火花。
Beryllium copper/aluminum bronze material, non-sparking safely to be used.

货号		规格		重量(g)	
铝青铜合金	铍青铜合金	L(mm)	Kmax(mm)	铝青铜合金	铍青铜合金
AL130-1002	BE130-1002	200	25	365	400
AL130-1004	BE130-1004	250	30	560	615
AL130-1006	BE130-1006	300	40	750	825
AL130-1008	BE130-1008	350	50	1000	1100
AL130-1010	BE130-1010	450	60	1625	1785
AL130-1012	BE130-1012	600	75	2960	3255
AL130-1014	BE130-1014	900	125	5490	6035
AL130-1016	BE130-1016	1200	150	10870	12280

防爆德式轻型管钳
Wrench, Pipe (Germany Light Type)



● 一次性模锻而成，硬度高，使用省力。
One-time die-forged, high hardness and labor saving.
● 铍青铜/铝青铜材质，使用安全无火花。
Beryllium copper/aluminum bronze material, non-sparking safely to be used.

货号		规格		重量(g)	
铝青铜合金	铍青铜合金	L(mm)	Kmax(mm)	铝青铜合金	铍青铜合金
AL130C-1002	BE130C-1002	350	75	1200	1300

防爆斜管钳
Wrench, Pipe (Diagonal Type)

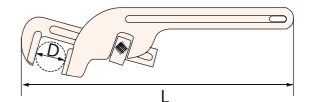

● 用于夹持、装配和拆卸管件和轴类零件。手柄倾斜45°，适用于特殊空间。
Used for clamping, assembling and dismantling pipes and shaft parts. Handle tilts 45° for special spaces.
● 一次性模锻而成，硬度高，使用省力。
One-time die-forged, high hardness and labor saving.
● 铍青铜/铝青铜材质，使用安全无火花。
Beryllium copper/aluminum bronze material, non-sparking safely to be used.

货号		规格		重量(g)	
铝青铜合金	铍青铜合金	L(mm)	Dmax(mm)	铝青铜合金	铍青铜合金
AL131B-1002	BE131B-1002	200	34	510	560
AL131B-1004	BE131B-1004	250	48	840	930
AL131B-1006	BE131B-1006	300	50	1330	1470
AL131B-1008	BE131B-1008	375	60	1610	1780
AL131B-1010	BE131B-1010	450	76	2400	2650

防爆弯管钳
Wrench, Pipe (Bent Type)

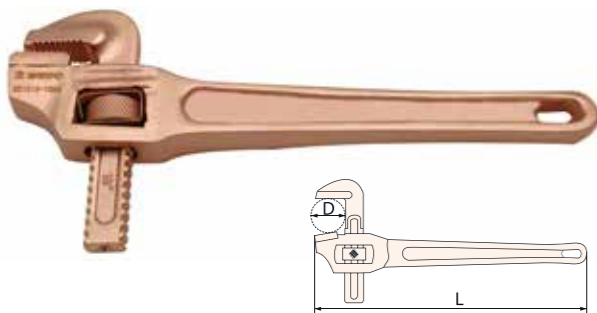

- 用于夹持、装配和拆卸管件和轴类零件。手柄倾斜90°，适用于特殊空间。
Used for clamping, assembling and dismantling pipes and shaft parts. Handle tilts 90° for special spaces.
- 一次性模锻而成，硬度高，使用省力。
One-time die-forged, high hardness and labor saving.
- 铍青铜/铝青铜材质，使用安全无火花。
Beryllium copper/aluminum bronze material, non-sparking safely to be used.

货号		规格		重量(g)	
铝青铜合金	铍青铜合金	L(mm)	Dmax(mm)	铝青铜合金	铍青铜合金
AL131C-1002	BE131C-1002	200	34	450	500
AL131C-1004	BE131C-1004	250	48	780	850
AL131C-1006	BE131C-1006	300	50	1090	1200
AL131C-1008	BE131C-1008	375	60	1770	1950
AL131C-1010	BE131C-1010	450	76	2480	2730

防爆六角弯管钳
Wrench, Pipe (Bent & Hex Type)

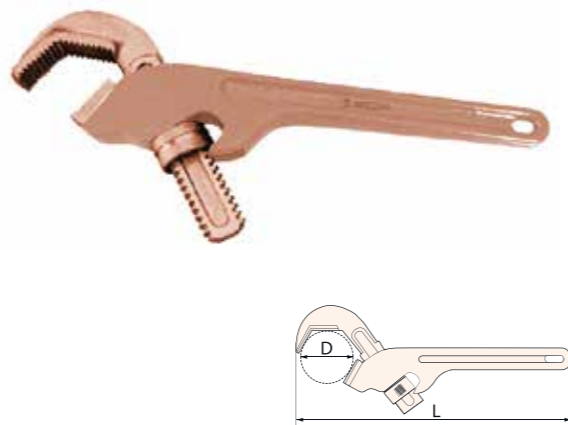

- 用于夹持、装配和拆卸管件和轴类零件。手柄倾斜45°，适用于特殊空间。
Used for clamping, assembling and dismantling pipes and shaft parts. Handle tilts 45° for special spaces.

货号		规格		重量(g)	
铝青铜合金	铍青铜合金	L(mm)	Dmax(mm)	铝青铜合金	铍青铜合金
AL131E-1002	BE131E-1002	250	30	1130	1250
AL131E-1004	BE131E-1004	350	50	1620	1785

防爆呆梅两用扳手
Wrench, Combination

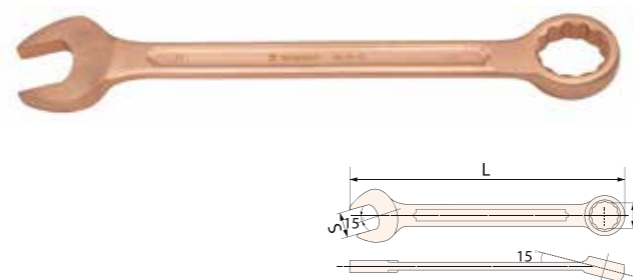

- 两端适用相同规格的螺栓、螺母的拆装，15°角的偏移，更有利于操作。
Both ends can be used for same size of bolts and nuts. Wrench tilts 15 degrees for high-efficiency operation.

货号		规格		重量(g)	
铝青铜合金	铍青铜合金	S(mm)	L(mm)	铝青铜合金	铍青铜合金
AL135-6	BE135-6	6	105	20	22
AL135-7	BE135-7	7	120	34	37
AL135-8	BE135-8	8	120	34	37
AL135-9	BE135-9	9	135	50	55
AL135-10	BE135-10	10	135	50	55
AL135-11	BE135-11	11	150	75	75
AL135-12	BE135-12	12	150	70	75
AL135-13	BE135-13	13	175	110	122
AL135-14	BE135-14	14	175	110	122
AL135-15	BE135-15	15	195	145	160
AL135-16	BE135-16	16	195	140	155
AL135-17	BE135-17	17	195	140	155
AL135-18	BE135-18	18	215	190	210
AL135-19	BE135-19	19	215	190	210
AL135-20	BE135-20	20	230	200	225
AL135-21	BE135-21	21	230	200	225
AL135-22	BE135-22	22	2545	220	250
AL135-23	BE135-23	23	265	233	265
AL135-24	BE135-24	24	265	230	260
AL135-25	BE135-25	25	265	230	260
AL135-26	BE135-26	26	290	380	420
AL135-27	BE135-27	27	290	380	420
AL135-30	BE135-30	30	320	500	560
AL135-32	BE135-32	32	340	600	670
AL135-34	BE135-34	34	360	750	850
AL135-35	BE135-35	35	360	800	890
AL135-36	BE135-36	36	360	800	890
AL135-38	BE135-38	38	395	1150	1200
AL135-41	BE135-41	41	460	1300	1440
AL135-46	BE135-46	46	450	1700	1890
AL135-50	BE135-50	50	520	2000	2220
AL135-55	BE135-55	55	560	2230	2460
AL135-60	BE135-60	60	595	2950	3300
AL135-65	BE135-65	65	595	2900	3250
AL135-70	BE135-70	70	630	4100	4550

防爆呆梅两用扳手
Wrench, Combination

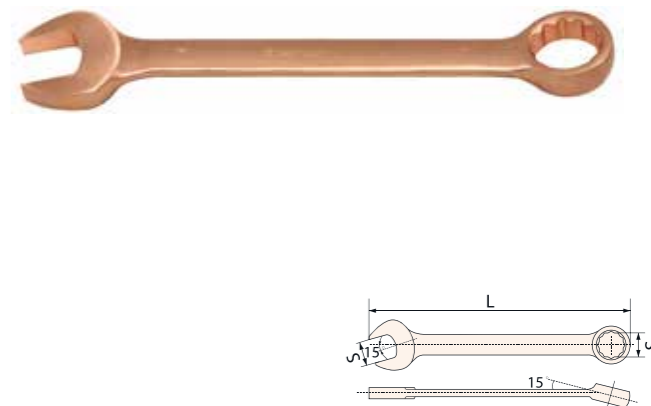

- 两端适用相同规格的螺栓、螺母的拆装，15°角的偏移，更有利于操作。
Both ends can be used for same size of bolts and nuts. Wrench tilts 15 degrees for high-efficiency operation.

- 铍青铜/铝青铜材质，使用安全无火花。
Beryllium copper/aluminum bronze material, non-sparking safely to be used.
- 一次性模锻而成，硬度高，使用省力。
One-time die-forged, high hardness and labor saving.

货号		规格		重量(g)	
铝青铜合金	铍青铜合金	S(mm)	L(mm)	铝青铜合金	铍青铜合金
AL136-6	BE136-6	6	105	16	18
AL136-7	BE136-7	7	120	40	40
AL136-8	BE136-8	8	120	40	40
AL136-9	BE136-9	9	135	42	45
AL136-10	BE136-10	10	135	42	45
AL136-11	BE136-11	11	150	60	65
AL136-12	BE136-12	12	150	60	65
AL136-13	BE136-13	13	175	82	90
AL136-14	BE136-14	14	175	82	90
AL136-15	BE136-15	15	195	125	140
AL136-16	BE136-16	16	195	125	140
AL136-17	BE136-17	17	195	125	140
AL136-18	BE136-18	18	215	165	180
AL136-19	BE136-19	19	215	165	180
AL136-20	BE136-20	20	215	165	180
AL136-21	BE136-21	21	245	260	280
AL136-22	BE136-22	22	245	260	280
AL136-23	BE136-23	23	265	290	320
AL136-24	BE136-24	24	265	290	320
AL136-25	BE136-25	25	265	455	500
AL136-26	BE136-26	26	290	455	500
AL136-27	BE136-27	27	290	455	500
AL136-30	BE136-30	30	320	635	700
AL136-32	BE136-32	32	340	710	780
AL136-34	BE136-34	34	360	910	1000
AL136-36	BE136-36	36	360	910	1000
AL136-38	BE136-38	38	430	1310	1450
AL136-41	BE136-41	41	430	1190	1420
AL136-46	BE136-46	46	480	1590	1760
AL136-50	BE136-50	50	520	1830	2020
AL136-55	BE136-55	55	560	1810	2000
AL136-60	BE136-60	60	595	2640	2920
AL136-65	BE136-65	65	595	3110	3440
AL136-70	BE136-70	70	630	3730	4130
AL136-75	BE136-75	75	630	3620	4000
AL136-80	BE136-80	80	660	4880	5400
AL136-85	BE136-85	85	660	4800	5320
AL136-90	BE136-90	90	720	6410	7100
AL136-95	BE136-95	95	720	3250	7000
AL136-100	BE136-100	100	780	8100	8950
AL136-110	BE136-110	110	840	10369	11350
AL136-120	BE136-120	120	900	11560	12750

防爆六角直管钳
Wrench, Pipe (Hex Type)



- 用于夹持、装配和拆卸管件和轴类零件。钳口六角形状夹持更牢固，适用于特殊空间。
Used for clamping, dismantling and fastening pipes and shaft parts. Hexagonal jaw is stronger for special space.

货号		规格		重量(g)	
铝青铜合金	铍青铜合金	L(mm)	Dmax(mm)	铝青铜合金	铍青铜合金
AL131D-1002	BE131D-1002	250	30	1130	1250
AL131D-1004	BE131D-1004	350	50	1620	1785



防爆S型双头梅花扳手 Wrench, Double Box S Type

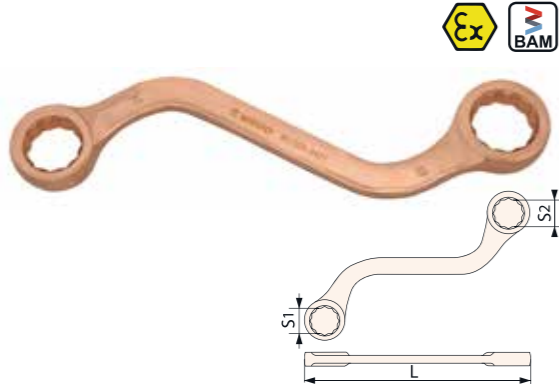

- 在狭窄、深凹处, 可用于紧固和拆卸六角螺栓和螺母。 Used to loosen and tighten hexagon bolts and nuts in narrow and deep space.

Table with columns: 货号, 规格, 重量(g). Rows list various sizes from 6*7 to 30*32, including material types like 铝青铜合金 and 铍青铜合金.

防爆平头双头梅花扳手 Wrench, Double Flat Box

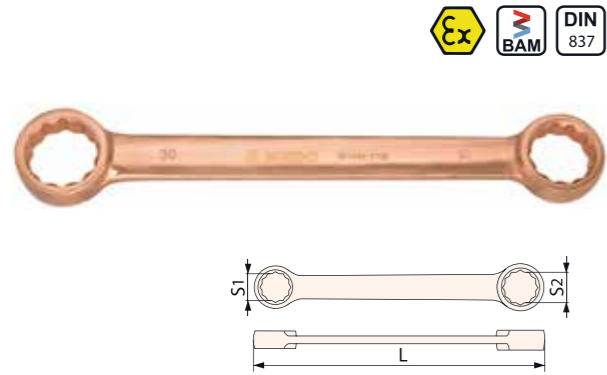

- 在狭窄、深凹处, 可用于紧固和拆卸六角螺栓和螺母。 Used to loosen and tighten hexagon bolts and nuts in narrow and deep space.

Table with columns: 货号, 规格, 重量(g). Rows list various sizes from 8*10 to 36*41, including material types like 铝青铜合金 and 铍青铜合金.

防爆油管扳手 Flare Nut Open Ring Wrench

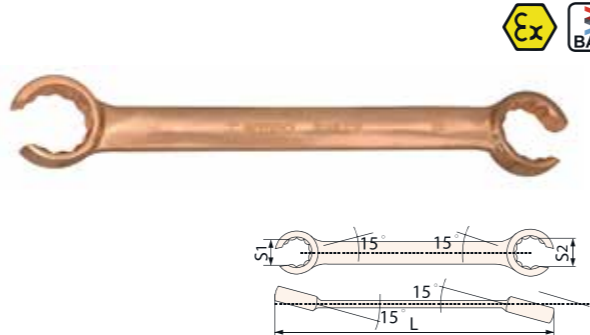

- 用于拆装油管外加螺帽、螺母。有缺口, 在管子上进退自如。 Used to loosen and tighten bolts and nuts on the ends of tubes. Small opening of wrench to facilitate operation.

Table with columns: 货号, 规格, 重量(g). Rows list various sizes from 6*7 to 36*41, including material types like 铝青铜合金 and 铍青铜合金.

防爆高颈撬棒梅花扳手 Wrench, Construction

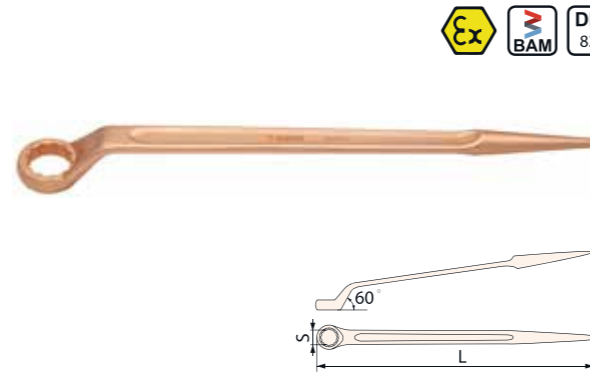

- 用于紧固和拆卸六角螺栓、螺母, 45°高颈有效避开障碍物, 长柄, 尖尾, 省力多用。 Used to loosen and tighten hexagon bolts and nuts. 45 degrees of deep offset can step aside the obstacles efficiently. Long handle with pin end, multipurpose, labor saving.

Table with columns: 货号, 规格, 重量(g). Rows list various sizes from 10 to 60, including material types like 铝青铜合金 and 铍青铜合金.

防爆撬棒梅花扳手 Wrench, Construction

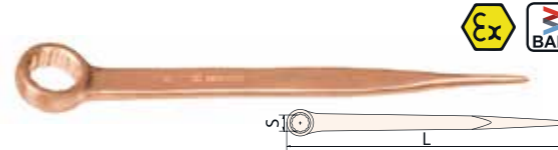

- 用于紧固和拆卸六角螺栓、螺母, 尖尾, 省力多用。 Used to loosen and tighten hexagon bolts and nuts. Long handle with pin end, multi-purpose, labor saving.

Table with columns: 货号, 规格, 重量(g). Rows list various sizes from 8 to 70, including material types like 铝青铜合金 and 铍青铜合金.

防爆直柄单头梅花扳手 Wrench, Single Box

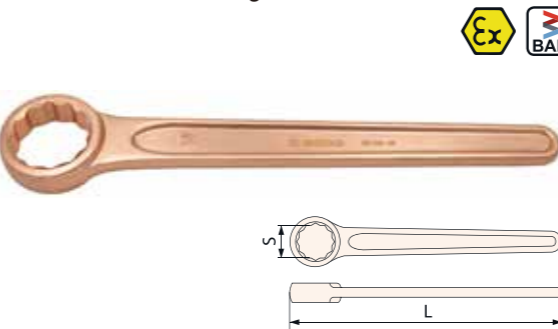

- 用于紧固和拆卸六角螺栓、螺母。 Used to loosen and tighten hexagon bolts and nuts.

Table with columns: 货号, 规格, 重量(g). Rows list various sizes from 8 to 75, including material types like 铝青铜合金 and 铍青铜合金.

防爆弯柄单头梅花扳手 Wrench, Single Bent Box

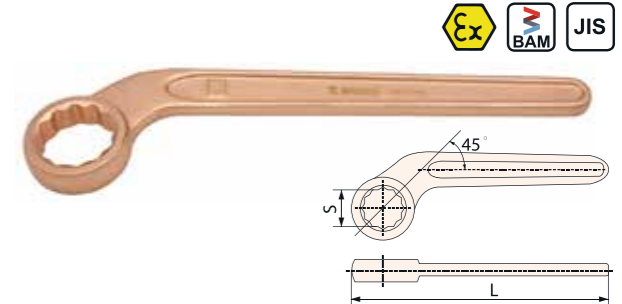

- 适用于狭窄、深凹处紧固和拆卸螺栓、螺母。 Used to loosen and tighten bolts and nuts in narrow or deep space.

Table with columns: 货号, 规格, 重量(g). Rows list various sizes from 10 to 80, including material types like 铝青铜合金 and 铍青铜合金.

防爆弯柄单头六角扳手 Wrench, Single Bent Box

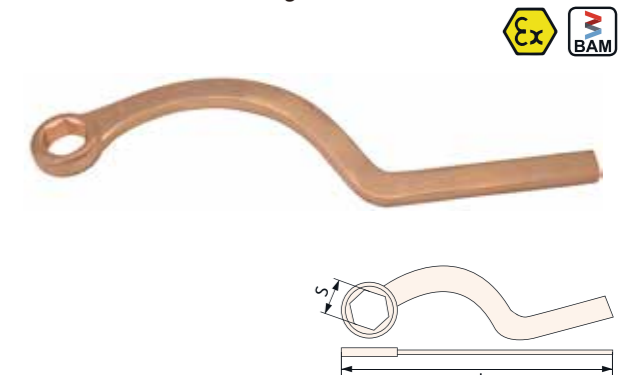

- 用于紧固和拆卸六角螺栓、螺母。 Used to loosen and tighten hexagon bolts and nuts. 铍青铜/铝青铜材质, 使用安全无火花。 Beryllium copper/aluminum bronze material, non-sparking safely to be used.

Table with columns: 货号, 规格, 重量(g). Rows list various sizes from 22 to 75, including material types like 铝青铜合金 and 铍青铜合金.

防爆倒装柄德式八角锤
Hammer, Sledge(German Type)

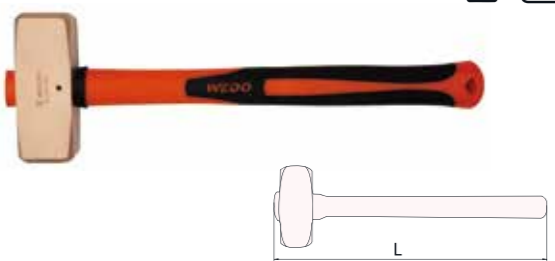

● 锤头和锤柄不会脱落,实现了锤子永不掉头。
New design fixing-system, increased the safety of users.

货号		规格		重量(g)	
铝青铜合金	铍青铜合金	HEAD(g)	L(mm)	铝青铜合金	铍青铜合金
AL192B-1004	BE192B-1004	1000	370	1300	1300
AL192B-1006	BE192B-1006	1500	370	1800	1800
AL192B-1008	BE192B-1008	2000	370	2300	2300
AL192B-1010	BE192B-1010	3000	700	3950	3950
AL192B-1012	BE192B-1012	4000	900	4950	4950
AL192B-1014	BE192B-1014	5000	900	5950	5950

防爆线锤
Hammer Plumb

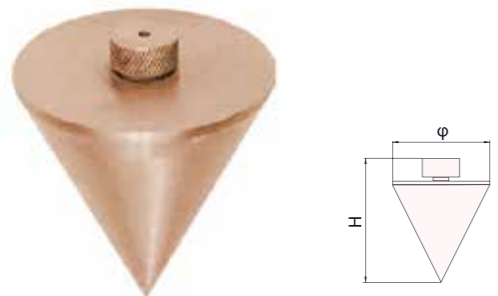

● 在易燃易爆场所安装设备时,做垂直基础线用。
Provide vertical base line for installation in inflammable and explosive place.

货号		规格		重量(g)	
铝青铜合金	铍青铜合金	H(mm)	Φ(mm)	铝青铜合金	铍青铜合金
AL193-1002	BE193-1002	59	50	247	275

防爆装柄镐头
Pick Railroad

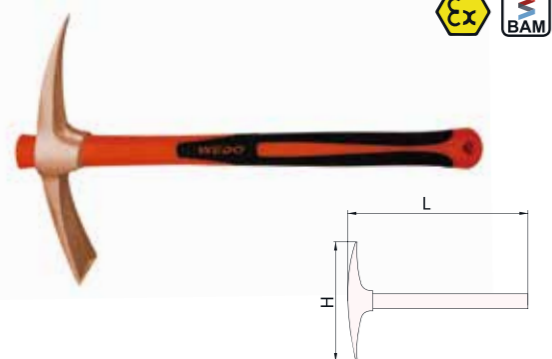

● 用于易燃易爆场所,挖掘、维修专用工具。
Used for excavation and maintenance in inflammable and explosive place.

货号		规格			重量(g)	
铝青铜合金	铍青铜合金	Size	H(mm)	L(mm)	铝青铜合金	铍青铜合金
AL194-1002	BE194-1002	1#	360	910	2000	2100
AL194-1004	BE194-1004	2#	385	910	2800	2950
AL194-1006	BE194-1006	3#	410	910	3200	3385
AL194-1008	BE194-1008	4#	470	910	3500	3715

防爆双尖镐头
Pick Railroad

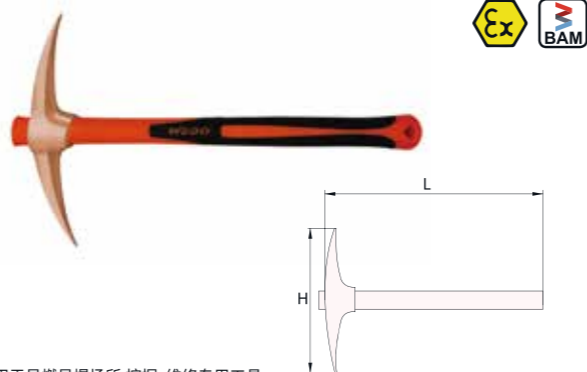

● 用于易燃易爆场所,挖掘、维修专用工具。
Special for excavation and maintenance in inflammable and explosive place.

货号		规格			重量(g)	
铝青铜合金	铍青铜合金	Size	L(mm)	铝青铜合金	铍青铜合金	
AL194A-1002	BE194A-1002	1#	910	2000	2100	
AL194A-1004	BE194A-1004	2#	910	2800	2950	
AL194A-1006	BE194A-1006	3#	910	3200	3385	
AL194A-1008	BE194A-1008	4#	910	4000	4330	

防爆装柄安全斧
Axe Fireman

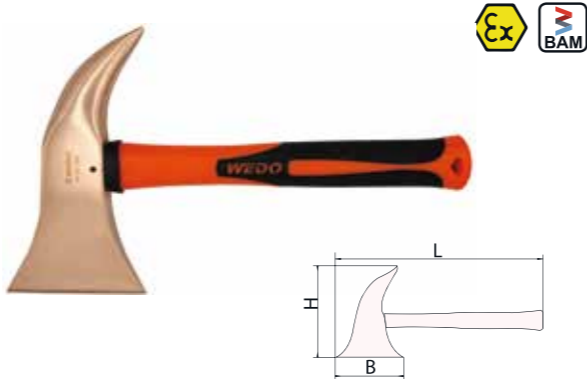

● 在易燃易爆场所,刃端用于砍制,尖端用于消防破拆作业。
Use the blade end for cutting, and the tip end for forcible entry by firefighters in inflammable and explosive place.

货号		规格			重量(g)	
铝青铜合金	铍青铜合金	L(mm)	H(mm)	B(mm)	铝青铜合金	铍青铜合金
AL195-1002	BE195-1002	340	190	98	1300	1425

防爆装柄双刃斧
Axe



● 在易燃易爆场所,用于砍制,斧顶用于敲击。
Used for cutting, and the top of axe for striking in inflammable and explosive place.

货号		规格			重量(g)	
铝青铜合金	铍青铜合金	L(mm)	H(mm)	B(mm)	铝青铜合金	铍青铜合金
AL196-1002	BE196-1002	340	145	82	890	980

防爆长柄消防斧
Axe, Pick Head

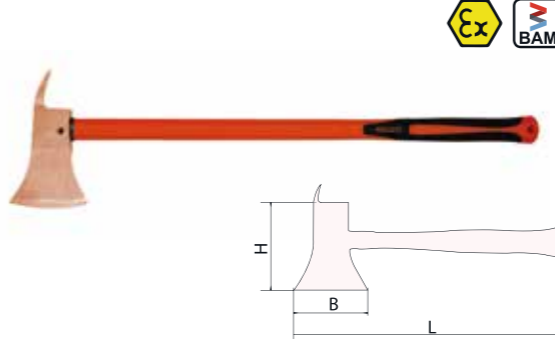

● 在易燃易爆场所,用于砍制,斧顶用于敲击。
Used for cutting, and the top of axe for striking in inflammable and explosive place.

货号		规格			重量(g)	
铝青铜合金	铍青铜合金	Size(g)	L(mm)	B(mm)	铝青铜合金	铍青铜合金
AL196A-1002	BE196A-1002	1800	920	120	2650	2650

防爆砧台
Anvil Block

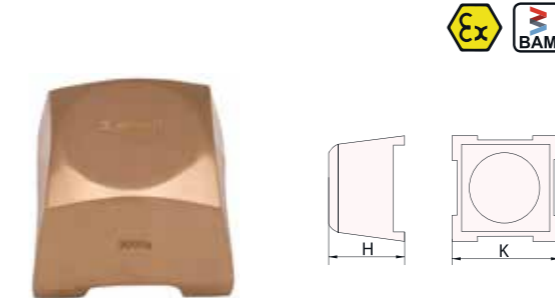

● 锻工锻制工件用。
Used for forging.

货号		规格		
铝青铜合金	铍青铜合金	Size(g)	H(mm)	K(mm)
AL197-1002	BE197-1002	3000	63	92
AL197-1004	BE197-1004	5000	75	111
AL197-1006	BE197-1006	16000	114	160

防爆装柄方锹
Shovel, Square

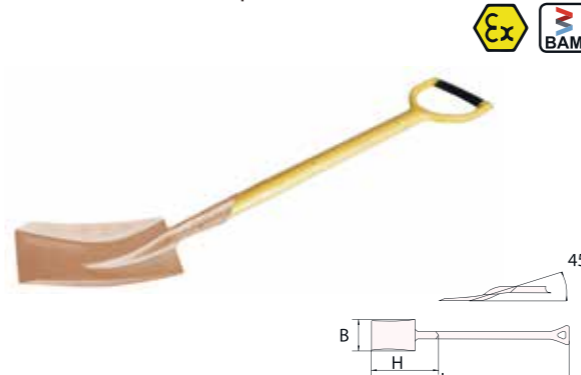

● 用于铲装易燃易爆的药品及颗粒状化学物品。
Used for shoveling and lifting inflammable and explosive medicines and granular chemicals.

货号		规格			重量(g)	
铝青铜合金	铍青铜合金	L(mm)	B(mm)	H(mm)	铝青铜合金	铍青铜合金
AL198-1002	BE198-1002	940	175	340	1290	1410
AL198-1004	BE198-1004	990	240	418	1650	1804

防爆长柄方锹
Shovel, Square

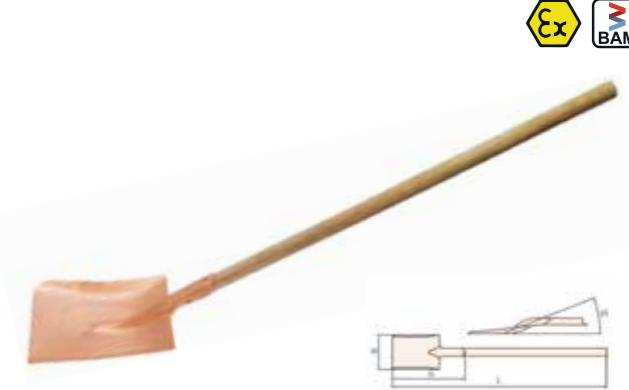

● 用于铲装易燃易爆的药品及颗粒状化学物品。
For digging, lifting, and moving medicines and granular chemicals.

货号		规格			重量(g)	
铝青铜合金	铍青铜合金	L(mm)	B(mm)	H(mm)	铝青铜合金	铍青铜合金
AL198A-1002	BE198A-1002	1400	175	340	1680	1800
AL198A-1004	BE198A-1004	1450	240	418	2050	2200

防爆欧式长柄大方锹
Shovel, Square(Euro Type)

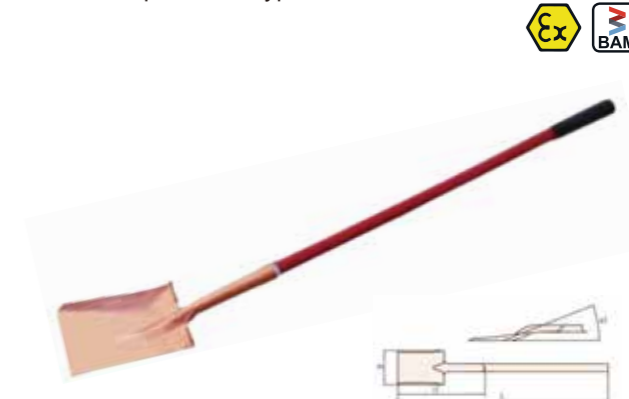

● 用于铲装易燃易爆的药品及颗粒状化学物品。
For digging, lifting, and moving medicines and granular chemicals.

货号		规格			重量(g)	
铝青铜合金	铍青铜合金	L(mm)	B(mm)	H(mm)	铝青铜合金	铍青铜合金
AL198B-1002	BE198B-1002	1900	250	505	2550	2700

防爆长柄小方锹
Shovel, Square With Long Handle

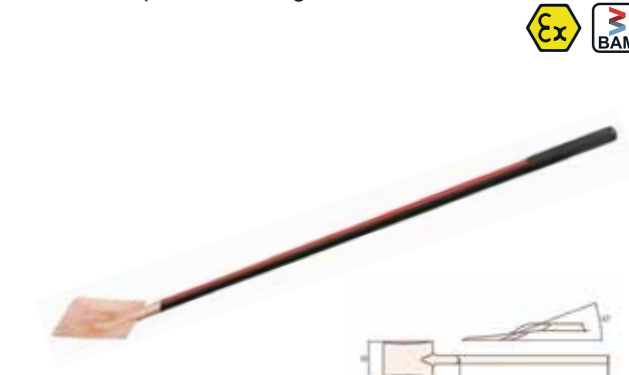

● 用于铲装易燃易爆的药品及颗粒状化学物品。
For digging, lifting, and moving medicines and granular chemicals.

货号		规格			重量(g)	
铝青铜合金	铍青铜合金	L(mm)	B(mm)	H(mm)	铝青铜合金	铍青铜合金
AL198C-1002	BE198C-1002	1750	190	340	1620	1750

防爆工具系列
NON-SPARKING TOOLS

防爆工具系列
NON-SPARKING TOOLS

防爆装柄煤锹

Dust Pan



● 用于铲装易燃易爆的药品及颗粒状化学物品。
For digging, lifting, and moving medicines and granular chemicals.

货号		规格			重量(g)	
铝青铜合金	铍青铜合金	L(mm)	B(mm)	H(mm)	铝青铜合金	铍青铜合金
AL199-1002	BE199-1002	990	270	520	2130	2330

防爆日式小尖锹

Shovel, Round Point



● 用于铲装易燃易爆的药品及颗粒状化学物品。
For digging, lifting, and moving medicines and granular chemicals.

货号		规格			重量(g)	
铝青铜合金	铍青铜合金	L(mm)	B(mm)	H(mm)	铝青铜合金	铍青铜合金
AL200A-1002	BE200A-1002	830	170	300	1220	1300

防爆两用锹

Folding Square

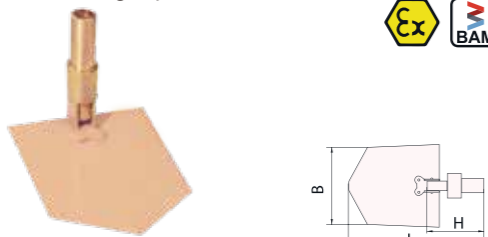

● 锹板和柄之间可水平使用,也可调为90°使用。
The angle between shovel and handle can be switched from 90 degree to 180 degree.

货号		规格			重量(g)	
铝青铜合金	铍青铜合金	L(mm)	B(mm)	H(mm)	铝青铜合金	铍青铜合金
AL200A-1002	BE200A-1002	830	170	300	1220	1300

防爆军工锹锤

Shovel, Military



● 用于铲装易燃易爆的药品及颗粒状化学物品。
For digging, lifting, and moving medicines and granular chemicals.

货号		规格			重量(g)	
铝青铜合金	铍青铜合金	L(mm)	H(mm)	铝青铜合金	铍青铜合金	
AL201C-1002	BE201C-1002	590	420	1300	1370	

防爆装柄尖锹

Shovel, Round Point

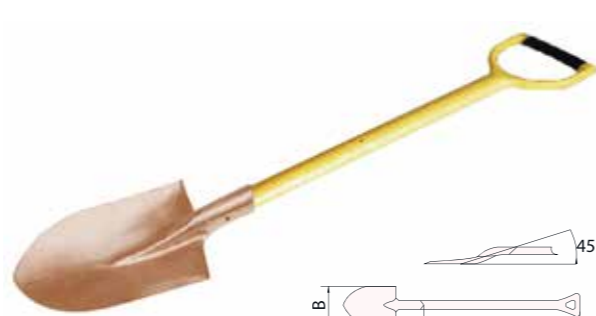

● 用于铲装易燃易爆的药品及颗粒状化学物品。
For digging, lifting, and moving medicines and granular chemicals.

货号		规格			重量(g)	
铝青铜合金	铍青铜合金	L(mm)	H(mm)	B(mm)	铝青铜合金	铍青铜合金
AL200-1002	BE200-1002	990	240	420	1420	1553

防爆长柄尖锹

Shovel, Round Point



● 用于铲装易燃易爆的药品及颗粒状化学物品。
For digging, lifting, and moving medicines and granular chemicals.

货号		规格			重量(g)	
铝青铜合金	铍青铜合金	L(mm)	B(mm)	H(mm)	铝青铜合金	铍青铜合金
AL200B-1002	BE200B-1002	1450	240	420	1420	1553

防爆推雪铲

Shovel, Snow



● 用于铲装易燃易爆的药品及颗粒状化学物品。
For digging, lifting, and moving medicines and granular chemicals.

货号		规格		重量(g)
黄铜		L(mm)	B(mm)	黄铜
BR201B-1002		1480	570	2500

防爆掘锹

Edging Spade

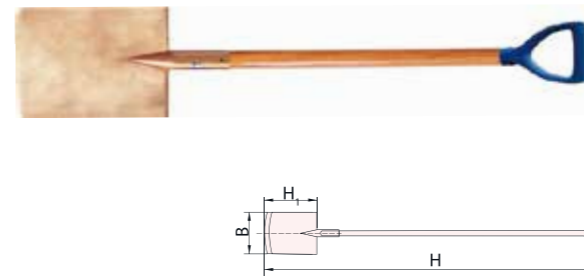

● 易燃易爆场所专用挖掘用具,强度高。
Special for excavation in inflammable and explosive place, with high strength.

货号		规格			重量(g)	
铝青铜合金	铍青铜合金	H(mm)	B(mm)	H ₁ (mm)	铝青铜合金	铍青铜合金
AL201A-1002	BE201A-1002	1390	195	290	3200	3500
AL201A-1004	BE201A-1004	1440	175	340	3480	3700

防爆(塑把)大方锹

Shovel, Square (plastic D-handle)



● 表面处理颜色为材质自然色或局部静电喷涂处理,不同材质的锹系列具有它的特殊专业性,各用于不同的环境、场所挖掘、清淤、装卸。
The surface treatment of natural color and partially electrostatic spraying are available, shovels of different materials have its special professionalism, can be applied for digging, removing silt, uploading and unloading in different environment.

货号		规格	
铝青铜合金	铍青铜合金	L(mm)	B(mm)
AL1981-1002	BE1981-1002	970	240

防爆(铜箍)大方锹

Shovel, Square (bronze hoop)



● 表面处理颜色为材质自然色或局部静电喷涂处理,不同材质的锹系列具有它的特殊专业性,各用于不同的环境、场所挖掘、清淤、装卸。
The surface treatment of natural color and partially electrostatic spraying are available, shovels of different materials have its special professionalism, can be applied for digging, removing silt, uploading and unloading in different environment.

货号		规格	
铝青铜合金	铍青铜合金	L(mm)	B(mm)
AL1982-1002	BE1982-1002	1390	240

防爆(防滑胶把)大方锹

Shovel, Square (anti-skid sleeve)



● 表面处理颜色为材质自然色或局部静电喷涂处理,不同材质的锹系列具有它的特殊专业性,各用于不同的环境、场所挖掘、清淤、装卸。
The surface treatment of natural color and partially electrostatic spraying are available, shovels of different materials have its special professionalism, can be applied for digging, removing silt, uploading and unloading in different environment.

货号		规格	
铝青铜合金	铍青铜合金	L(mm)	B(mm)
AL1983-1002	BE1983-1002	1410	240

防爆(塑把)平裤锁箍大方锹

Shovel, Square with locking clip (plastic D-handle)



● 表面处理颜色为材质自然色或局部静电喷涂处理,不同材质的锹系列具有它的特殊专业性,各用于不同的环境、场所挖掘、清淤、装卸。
The surface treatment of natural color and partially electrostatic spraying are available, shovels of different materials have its special professionalism, can be applied for digging, removing silt, uploading and unloading in different environment.

货号		规格	
铝青铜合金	铍青铜合金	L(mm)	B(mm)
AL1984-1002	BE1984-1002	970	240

防爆(铜箍)平裤锁箍大方锹

Shovel, Square with locking clip (bronze hoop)



● 表面处理颜色为材质自然色或局部静电喷涂处理,不同材质的锹系列具有它的特殊专业性,各用于不同的环境、场所挖掘、清淤、装卸。
The surface treatment of natural color and partially electrostatic spraying are available, shovels of different materials have its special professionalism, can be applied for digging, removing silt, uploading and unloading in different environment.

货号		规格	
铝青铜合金	铍青铜合金	L(mm)	B(mm)
AL1985-1002	BE1985-1002	1390	240

防爆(防滑胶把)平锹锁箍大方锹

Shovel, Square with locking clip (anti-skid sleeve)



● 表面处理颜色为材质自然色或局部静电喷涂处理, 不同材质的锹系列具有它的特殊专业性, 各用于不同的环境、场所挖掘、清淤、装卸。
The surface treatment of natural color and partially electrostatic spraying are available, shovels of different materials have its special professionalism, can be applied for digging, removing silt, uploading and unloading in different environment.

货号		规格	
铝青铜合金	铍青铜合金	L(mm)	B(mm)
AL1986-1002	BE1986-1002	1410	240

防爆(塑把)三方锹

Shovel, Square (plastic D-handle)



● 表面处理颜色为材质自然色或局部静电喷涂处理, 不同材质的锹系列具有它的特殊专业性, 各用于不同的环境、场所挖掘、清淤、装卸。
The surface treatment of natural color and partially electrostatic spraying are available, shovels of different materials have its special professionalism, can be applied for digging, removing silt, uploading and unloading in different environment.

货号		规格	
铝青铜合金	铍青铜合金	L(mm)	B(mm)
AL1987-1002	BE1987-1002	970	195

防爆(铜箍)三方锹

Shovel, Square (bronze hoop)



● 表面处理颜色为材质自然色或局部静电喷涂处理, 不同材质的锹系列具有它的特殊专业性, 各用于不同的环境、场所挖掘、清淤、装卸。
The surface treatment of natural color and partially electrostatic spraying are available, shovels of different materials have its special professionalism, can be applied for digging, removing silt, uploading and unloading in different environment.

货号		规格	
铝青铜合金	铍青铜合金	L(mm)	B(mm)
AL1988-1002	BE1988-1002	1200	195

防爆(防滑胶把)三方锹

Shovel, Square (anti-skid sleeve)



● 表面处理颜色为材质自然色或局部静电喷涂处理, 不同材质的锹系列具有它的特殊专业性, 各用于不同的环境、场所挖掘、清淤、装卸。
The surface treatment of natural color and partially electrostatic spraying are available, shovels of different materials have its special professionalism, can be applied for digging, removing silt, uploading and unloading in different environment.

货号		规格	
铝青铜合金	铍青铜合金	L(mm)	B(mm)
AL1989-1002	BE1989-1002	1220	195

防爆(塑柄)长方锹

Shovel, Square (plastic D-handle)



● 表面处理颜色为材质自然色或局部静电喷涂处理, 不同材质的锹系列具有它的特殊专业性, 各用于不同的环境、场所挖掘、清淤、装卸。
The surface treatment of natural color and partially electrostatic spraying are available, shovels of different materials have its special professionalism, can be applied for digging, removing silt, uploading and unloading in different environment.

货号		规格	
铝青铜合金	铍青铜合金	L(mm)	B(mm)
AL1990-1002	BE1990-1002	1020	180

防爆(铜箍)长方锹

Shovel, Square (bronze hoop)



● 表面处理颜色为材质自然色或局部静电喷涂处理, 不同材质的锹系列具有它的特殊专业性, 各用于不同的环境、场所挖掘、清淤、装卸。
The surface treatment of natural color and partially electrostatic spraying are available, shovels of different materials have its special professionalism, can be applied for digging, removing silt, uploading and unloading in different environment.

货号		规格	
铝青铜合金	铍青铜合金	L(mm)	B(mm)
AL1991-1002	BE1991-1002	1200	180

防爆(防滑胶把)长方锹

Shovel, Square (anti-skid sleeve)



● 表面处理颜色为材质自然色或局部静电喷涂处理, 不同材质的锹系列具有它的特殊专业性, 各用于不同的环境、场所挖掘、清淤、装卸。
The surface treatment of natural color and partially electrostatic spraying are available, shovels of different materials have its special professionalism, can be applied for digging, removing silt, uploading and unloading in different environment.

货号		规格	
铝青铜合金	铍青铜合金	L(mm)	B(mm)
AL1992-1002	BE1992-1002	1220	180

防爆(塑把)弯颈长裤锁箍方锹

Shovel, Square Long Bent neck with D-handle (American Type)



● 表面处理颜色为材质自然色或局部静电喷涂处理, 不同材质的锹系列具有它的特殊专业性, 各用于不同的环境、场所挖掘、清淤、装卸。
The surface treatment of natural color and partially electrostatic spraying are available, shovels of different materials have its special professionalism, can be applied for digging, removing silt, uploading and unloading in different environment.

货号		规格	
铝青铜合金	铍青铜合金	L(mm)	B(mm)
AL1993-1002	BE1993-1002	1100	235

防爆(铜箍)弯颈长裤锁箍方锹

Shovel, Square Long Bent neck with bronze hoop (American Type)



● 表面处理颜色为材质自然色或局部静电喷涂处理, 不同材质的锹系列具有它的特殊专业性, 各用于不同的环境、场所挖掘、清淤、装卸。
The surface treatment of natural color and partially electrostatic spraying are available, shovels of different materials have its special professionalism, can be applied for digging, removing silt, uploading and unloading in different environment.

货号		规格	
铝青铜合金	铍青铜合金	L(mm)	B(mm)
AL1994-1002	BE1994-1002	1390	235

防爆(防滑胶把)弯颈长裤锁箍方锹

Shovel, Square Long Bent neck with anti-skid sleeve (American Type)



● 表面处理颜色为材质自然色或局部静电喷涂处理, 不同材质的锹系列具有它的特殊专业性, 各用于不同的环境、场所挖掘、清淤、装卸。
The surface treatment of natural color and partially electrostatic spraying are available, shovels of different materials have its special professionalism, can be applied for digging, removing silt, uploading and unloading in different environment.

货号		规格	
铝青铜合金	铍青铜合金	L(mm)	B(mm)
AL1995-1002	BE1995-1002	1410	235

防爆纤维柄弯颈长裤锁箍方锹

Shovel, Square Long Bent neck with fiberglass handle (American Type)



● 表面处理颜色为材质自然色或局部静电喷涂处理, 采用美国军工锹的优点生产, 用于不同的环境、场所挖掘、清淤、装卸, 使用更加牢固便捷。
The surface treatment of natural color and partially electrostatic spraying are available; adopt the advantages of American military shovels, which makes it more durable and convenient to use, can be applied for digging, removing silt, uploading and unloading in different environment.

货号		规格	
铝青铜合金	铍青铜合金	L(mm)	B(mm)
AL1996-1002	BE1996-1002	1530	235

防爆纤维柄直颈长裤锁箍方锹

Shovel, Square Long Straight neck with fiberglass handle (American Type)



● 表面处理颜色为材质自然色或局部静电喷涂处理, 采用美国军工锹的优点生产, 用于不同的环境、场所挖掘、清淤、装卸, 使用更加牢固便捷。
The surface treatment of natural color and partially electrostatic spraying are available; adopt the advantages of American military shovels, which makes it more durable and convenient to use, can be applied for digging, removing silt, uploading and unloading in different environment.

货号		规格	
铝青铜合金	铍青铜合金	L(mm)	B(mm)
AL1997-1002	BE1997-1002	1500	230

防爆(塑把)直颈长裤锁箍方锹

Shovel, Square Long Straight neck with D-handle (American Type)



● 表面处理颜色为材质自然色或局部静电喷涂处理, 采用美国军工锹的优点生产, 用于不同的环境、场所挖掘、清淤、装卸, 使用更加牢固便捷。
The surface treatment of natural color and partially electrostatic spraying are available; adopt the advantages of American military shovels, which makes it more durable and convenient to use, can be applied for digging, removing silt, uploading and unloading in different environment.

货号		规格	
铝青铜合金	铍青铜合金	L(mm)	B(mm)
AL1998-1002	BE1998-1002	1080	230

防爆(铜箍)直颈长裤锁箍方锹

Shovel, Square Long Straight neck with bronze hoop (American Type)



● 表面处理颜色为材质自然色或局部静电喷涂处理, 采用美国军工锹的优点生产, 用于不同的环境、场所挖掘、清淤、装卸, 使用更加牢固便捷。
The surface treatment of natural color and partially electrostatic spraying are available; adopt the advantages of American military shovels, which makes it more durable and convenient to use, can be applied for digging, removing silt, uploading and unloading in different environment.

货号		规格	
铝青铜合金	铍青铜合金	L(mm)	B(mm)
AL1999-1002	BE1999-1002	1390	230

防爆(防滑胶把)直颈长裤锁箍方锹

Shovel, Square Long Straight neck with anti-skid sleeve (American Type)



● 表面处理颜色为材质自然色或局部静电喷涂处理, 采用美国军工锹的优点生产, 用于不同的环境、场所挖掘、清淤、装卸, 使用更加牢固便捷。
The surface treatment of natural color and partially electrostatic spraying are available; adopt the advantages of American military shovels, which makes it more durable and convenient to use, can be applied for digging, removing silt, uploading and unloading in different environment.

货号		规格	
铝青铜合金	铍青铜合金	L(mm)	B(mm)
AL2000-1002	BE2000-1002	1410	230

防爆(塑把)弯颈长裤小方锹

Shovel, Square Long Bent neck with D-handle (American Type)



● 表面处理颜色为材质自然色或局部静电喷涂处理, 采用美国军工锹的优点生产, 用于不同的环境、场所挖掘、清淤、装卸, 使用更加牢固便捷。
The surface treatment of natural color and partially electrostatic spraying are available; adopt the advantages of American military shovels, which makes it more durable and convenient to use, can be applied for digging, removing silt, uploading and unloading in different environment.

货号		规格	
铝青铜合金	铍青铜合金	L(mm)	B(mm)
AL2001-1002	BE2001-1002	700	150

防爆(铜箍)弯颈长裤小方锹

Shovel, Square Long Bent neck with bronze hoop (American Type)



● 表面处理颜色为材质自然色或局部静电喷涂处理, 采用美国军工锹的优点生产, 用于不同的环境、场所挖掘、清淤、装卸, 使用更加牢固便捷。
The surface treatment of natural color and partially electrostatic spraying are available; adopt the advantages of American military shovels, which makes it more durable and convenient to use, can be applied for digging, removing silt, uploading and unloading in different environment.

货号		规格	
铝青铜合金	铍青铜合金	L(mm)	B(mm)
AL2002-1002	BE2002-1002	840	150

防爆(防滑胶把)弯颈长裤小方锹

Shovel, Square Long Bent neck with anti-skid sleeve (American Type)



● 表面处理颜色为材质自然色或局部静电喷涂处理, 采用美国军工锹的优点生产, 用于不同的环境、场所挖掘、清淤、装卸, 使用更加牢固便捷。
The surface treatment of natural color and partially electrostatic spraying are available; adopt the advantages of American military shovels, which makes it more durable and convenient to use, can be applied for digging, removing silt, uploading and unloading in different environment.

货号		规格	
铝青铜合金	铍青铜合金	L(mm)	B(mm)
AL2003-1002	BE2003-1002	860	150

防爆(塑把)尖锹

Shovel, Round Point (plastic D-handle)



● 表面处理颜色为材质自然色或局部静电喷涂处理, 不同材质的锹系列具有它的特殊专业性, 各用于不同的环境、场所挖掘、清淤、装卸。
The surface treatment of natural color and partially electrostatic spraying are available, shovels of different materials have its special professionalism, can be applied for digging, removing silt, uploading and unloading in different environment.

货号		规格	
铝青铜合金	铍青铜合金	L(mm)	B(mm)
AL2004-1002	BE2004-1002	1030	235

防爆(铜箍)尖锹

Shovel, Round Point (bronze hoop)



● 表面处理颜色为材质自然色或局部静电喷涂处理, 不同材质的锹系列具有它的特殊专业性, 各用于不同的环境、场所挖掘、清淤、装卸。
The surface treatment of natural color and partially electrostatic spraying are available, shovels of different materials have its special professionalism, can be applied for digging, removing silt, uploading and unloading in different environment.

货号		规格	
铝青铜合金	铍青铜合金	L(mm)	B(mm)
AL2005-1002	BE2005-1002	1200	235

防爆(防滑胶把)尖锹

Shovel, Round Point (anti-skid sleeve)



● 表面处理颜色为材质自然色或局部静电喷涂处理, 不同材质的锹系列具有它的特殊专业性, 各用于不同的环境、场所挖掘、清淤、装卸。
The surface treatment of natural color and partially electrostatic spraying are available, shovels of different materials have its special professionalism, can be applied for digging, removing silt, uploading and unloading in different environment.

货号		规格	
铝青铜合金	铍青铜合金	L(mm)	B(mm)
AL2006-1002	BE2006-1002	1220	235

防爆(塑把)长尖锹

Shovel, Round Point Long Type (plastic D-handle)



● 表面处理颜色为材质自然色或局部静电喷涂处理, 不同材质的锹系列具有它的特殊专业性, 各用于不同的环境、场所挖掘、清淤、装卸, 更便捷。
The surface treatment of natural color and partially electrostatic spraying are available, shovels of different materials have its special professionalism, can be applied for digging, removing silt, uploading and unloading in different environment, more convenient.

货号		规格	
铝青铜合金	铍青铜合金	L(mm)	B(mm)
AL2007-1002	BE2007-1002	1030	180

防爆(铜箍)长尖锹

Shovel, Round Point Long Type (bronze hoop)



● 表面处理颜色为材质自然色或局部静电喷涂处理, 不同材质的锹系列具有它的特殊专业性, 各用于不同的环境、场所挖掘、清淤、装卸, 更便捷。
The surface treatment of natural color and partially electrostatic spraying are available, shovels of different materials have its special professionalism, can be applied for digging, removing silt, uploading and unloading in different environment, more convenient.

货号		规格	
铝青铜合金	铍青铜合金	L(mm)	B(mm)
AL2008-1002	BE2008-1002	1200	180

防爆(防滑胶把)长尖锹

Shovel, Round Point Long Type (anti-skid sleeve)



● 表面处理颜色为材质自然色或局部静电喷涂处理, 不同材质的锹系列具有它的特殊专业性, 各用于不同的环境、场所挖掘、清淤、装卸, 更便捷。
The surface treatment of natural color and partially electrostatic spraying are available, shovels of different materials have its special professionalism, can be applied for digging, removing silt, uploading and unloading in different environment, more convenient.

货号		规格	
铝青铜合金	铍青铜合金	L(mm)	B(mm)
AL2009-1002	BE2009-1002	1220	180

防爆(塑把)平裤锁箍尖锹

Shovel, Round Point With locking Clip
(Plastic D-handle)



● 表面处理颜色为材质自然色或局部静电喷涂处理, 不同材质的锹系列具有它的特殊专业性, 各用于不同的环境、场所挖掘、清淤、装卸, 柄与锹头连接更牢固。The surface treatment of natural color and partially electrostatic spraying are available, shovels of different materials have its special professionalism, can be applied for digging, removing silt, uploading and unloading in different environment, the connection of handle and shovels are more durable.

货号		规格	
铝青铜合金	铍青铜合金	L(mm)	B(mm)
AL2010-1002	BE2010-1002	1030	220

防爆(铜箍)平裤锁箍尖锹

Shovel, Round Point with locking clip
(bronze hoop)



● 表面处理颜色为材质自然色或局部静电喷涂处理, 不同材质的锹系列具有它的特殊专业性, 各用于不同的环境、场所挖掘、清淤、装卸, 柄与锹头连接更牢固。The surface treatment of natural color and partially electrostatic spraying are available, shovels of different materials have its special professionalism, can be applied for digging, removing silt, uploading and unloading in different environment, the connection of handle and shovels are more durable.

货号		规格	
铝青铜合金	铍青铜合金	L(mm)	B(mm)
AL2011-1002	BE2011-1002	1200	220

防爆(防滑胶把)平裤锁箍尖锹

Shovel, Round Point with locking clip
(anti-skid sleeve)



● 表面处理颜色为材质自然色或局部静电喷涂处理, 不同材质的锹系列具有它的特殊专业性, 各用于不同的环境、场所挖掘、清淤、装卸, 柄与锹头连接更牢固。The surface treatment of natural color and partially electrostatic spraying are available, shovels of different materials have its special professionalism, can be applied for digging, removing silt, uploading and unloading in different environment, the connection of handle and shovels are more durable.

货号		规格	
铝青铜合金	铍青铜合金	L(mm)	B(mm)
AL2012-1002	BE2012-1002	1220	220

防爆(塑把)日式小尖锹

Shovel, Round Point With Plastic D-handle
(Japanese Type)



● 表面处理颜色为材质自然色或局部静电喷涂处理, 不同材质的锹系列具有它的特殊专业性, 各用于不同的环境、场所挖掘、清淤、装卸。The surface treatment of natural color and partially electrostatic spraying are available, shovels of different materials have its special professionalism, can be applied for digging, removing silt, uploading and unloading in different environment.

货号		规格	
铝青铜合金	铍青铜合金	L(mm)	B(mm)
AL2013-1002	BE2013-1002	780	170

防爆(铜箍)日式小尖锹

Shovel, Round Point with bronze hoop (Japanese Type)



● 表面处理颜色为材质自然色或局部静电喷涂处理, 不同材质的锹系列具有它的特殊专业性, 各用于不同的环境、场所挖掘、清淤、装卸。The surface treatment of natural color and partially electrostatic spraying are available, shovels of different materials have its special professionalism, can be applied for digging, removing silt, uploading and unloading in different environment.

货号		规格	
铝青铜合金	铍青铜合金	L(mm)	B(mm)
AL2014-1002	BE2014-1002	780	170

防爆(防滑胶把)日式小尖锹

Shovel, Round Point with anti-skid sleeve (Japanese Type)



● 表面处理颜色为材质自然色或局部静电喷涂处理, 不同材质的锹系列具有它的特殊专业性, 各用于不同的环境、场所挖掘、清淤、装卸。The surface treatment of natural color and partially electrostatic spraying are available, shovels of different materials have its special professionalism, can be applied for digging, removing silt, uploading and unloading in different environment.

货号		规格	
铝青铜合金	铍青铜合金	L(mm)	B(mm)
AL2015-1002	BE2015-1002	800	170

防爆(塑把)弯颈长裤锁箍尖锹

Shovel, Round Point Long Bent neck
(plastic D-handle)



● 表面处理颜色为材质自然色或局部静电喷涂处理, 不同材质的锹系列具有它的特殊专业性, 各用于不同的环境、场所挖掘、清淤、装卸, 更便捷。The surface treatment of natural color and partially electrostatic spraying are available, shovels of different materials have its special professionalism, can be applied for digging, removing silt, uploading and unloading in different environment, more convenient.

货号		规格	
铝青铜合金	铍青铜合金	L(mm)	B(mm)
AL2016-1002	BE2016-1002	1030	210

防爆(铜箍)弯颈长裤锁箍尖锹

Shovel, Round Point Long Bent neck
(bronze hoop)



● 表面处理颜色为材质自然色或局部静电喷涂处理, 不同材质的锹系列具有它的特殊专业性, 各用于不同的环境、场所挖掘、清淤、装卸, 更便捷。The surface treatment of natural color and partially electrostatic spraying are available, shovels of different materials have its special professionalism, can be applied for digging, removing silt, uploading and unloading in different environment, more convenient.

货号		规格	
铝青铜合金	铍青铜合金	L(mm)	B(mm)
AL2017-1002	BE2017-1002	1200	210

防爆(防滑胶把)弯颈长裤锁箍尖锹

Shovel, Round Point Long Bent neck
(anti-skid sleeve)



● 表面处理颜色为材质自然色或局部静电喷涂处理, 不同材质的锹系列具有它的特殊专业性, 各用于不同的环境、场所挖掘、清淤、装卸, 更便捷。The surface treatment of natural color and partially electrostatic spraying are available, shovels of different materials have its special professionalism, can be applied for digging, removing silt, uploading and unloading in different environment, more convenient.

货号		规格	
铝青铜合金	铍青铜合金	L(mm)	B(mm)
AL2018-1002	BE2018-1002	1220	210

防爆纤维柄弯颈长裤锁箍尖锹

Shovel, Round Point Long Bent neck
(with fiberglass handle)



● 表面处理颜色为材质自然色或局部静电喷涂处理, 采用美国军工锹的优点生产, 用于不同的环境、场所挖掘、清淤、装卸, 使用更加牢固便捷。The surface treatment of natural color and partially electrostatic spraying are available; adopt the advantages of American military shovels, which makes it more durable and convenient to use, can be applied for digging, removing silt, uploading and unloading in different environment.

货号		规格	
铝青铜合金	铍青铜合金	L(mm)	B(mm)
AL2019-1002	BE2019-1002	1530	210

防爆(塑把)弯颈长裤小尖锹

Shovel, Round Point Long Bent neck (plastic D-handle)



● 表面处理颜色为材质自然色或局部静电喷涂处理, 采用美国军工锹的优点生产, 用于不同的环境、场所挖掘、清淤、装卸, 使用更加牢固便捷。The surface treatment of natural color and partially electrostatic spraying are available; adopt the advantages of American military shovels, which makes it more durable and convenient to use, can be applied for digging, removing silt, uploading and unloading in different environment.

货号		规格	
铝青铜合金	铍青铜合金	L(mm)	B(mm)
AL2020-1002	BE2020-1002	740	150

防爆(铜箍)弯颈长裤小尖锹

Shovel, Round Point Long Bent neck (bronze hoop)



● 表面处理颜色为材质自然色或局部静电喷涂处理, 采用美国军工锹的优点生产, 用于不同的环境、场所挖掘、清淤、装卸, 使用更加牢固便捷。The surface treatment of natural color and partially electrostatic spraying are available; adopt the advantages of American military shovels, which makes it more durable and convenient to use, can be applied for digging, removing silt, uploading and unloading in different environment.

货号		规格	
铝青铜合金	铍青铜合金	L(mm)	B(mm)
AL2021-1002	BE2021-1002	860	150

防爆(防滑胶把)弯颈长裤小尖锹

Shovel, Round Point Long Bent neck
(anti-skid sleeve)



● 表面处理颜色为材质自然色或局部静电喷涂处理, 采用美国军工锹的优点生产, 用于不同的环境、场所挖掘、清淤、装卸, 使用更加牢固便捷。
The surface treatment of natural color and partially electrostatic spraying are available; adopt the advantages of American military shovels, which makes it more durable and convenient to use, can be applied for digging, removing silt, uploading and unloading in different environment.

货号		规格	
铝青铜合金	铍青铜合金	L(mm)	B(mm)
AL2022-1002	BE2022-1002	860	150

防爆(塑把)直颈长裤锁箍小尖锹

Shovel, Round Point Long Straight neck
(plastic D-handle)



● 表面处理颜色为材质自然色或局部静电喷涂处理, 采用美国军工锹的优点生产, 用于不同的环境、场所挖掘、清淤、装卸, 使用更加牢固便捷。
The surface treatment of natural color and partially electrostatic spraying are available; adopt the advantages of American military shovels, which makes it more durable and convenient to use, can be applied for digging, removing silt, uploading and unloading in different environment.

货号		规格	
铝青铜合金	铍青铜合金	L(mm)	B(mm)
AL2023-1002	BE2023-1002	740	150

防爆(铜箍)直颈长裤锁箍小尖锹

Shovel, Round Point Long Straight neck
(bronze hoop)



● 表面处理颜色为材质自然色或局部静电喷涂处理, 采用美国军工锹的优点生产, 用于不同的环境、场所挖掘、清淤、装卸, 使用更加牢固便捷。
The surface treatment of natural color and partially electrostatic spraying are available; adopt the advantages of American military shovels, which makes it more durable and convenient to use, can be applied for digging, removing silt, uploading and unloading in different environment.

货号		规格	
铝青铜合金	铍青铜合金	L(mm)	B(mm)
AL2024-1002	BE2024-1002	860	150

防爆(防滑胶把)直颈长裤锁箍小尖锹

Shovel, Round Point Long Straight neck (anti-skid sleeve)



● 表面处理颜色为材质自然色或局部静电喷涂处理, 采用美国军工锹的优点生产, 用于不同的环境、场所挖掘、清淤、装卸, 使用更加牢固便捷。
The surface treatment of natural color and partially electrostatic spraying are available; adopt the advantages of American military shovels, which makes it more durable and convenient to use, can be applied for digging, removing silt, uploading and unloading in different environment.

货号		规格	
铝青铜合金	铍青铜合金	L(mm)	B(mm)
AL2025-1002	BE2025-1002	880	150

防爆(塑把)煤锹

Dust Pan with plastic D-handle



● 表面处理颜色为材质自然色或局部静电喷涂处理, 不同材质的锹系列具有它的特殊专业性, 各用于不同的环境、场所挖掘、清淤、装卸。
The surface treatment of natural color and partially electrostatic spraying are available, shovels of different materials have its special professionalism, can be applied for digging, removing silt, uploading and unloading in different environment.

货号		规格	
铝青铜合金	铍青铜合金	L(mm)	B(mm)
AL2026-1002	BE2026-1002	1030	280

防爆(铜箍)煤锹

Dust Pan with bronze hoop



● 表面处理颜色为材质自然色或局部静电喷涂处理, 不同材质的锹系列具有它的特殊专业性, 各用于不同的环境、场所挖掘、清淤、装卸。
The surface treatment of natural color and partially electrostatic spraying are available, shovels of different materials have its special professionalism, can be applied for digging, removing silt, uploading and unloading in different environment.

货号		规格	
铝青铜合金	铍青铜合金	L(mm)	B(mm)
AL2027-1002	BE2027-1002	1390	280

防爆(防滑胶把)煤锹

Dust Pan with anti-skid sleeve



● 表面处理颜色为材质自然色或局部静电喷涂处理, 不同材质的锹系列具有它的特殊专业性, 各用于不同的环境、场所挖掘、清淤、装卸。
The surface treatment of natural color and partially electrostatic spraying are available, shovels of different materials have its special professionalism, can be applied for digging, removing silt, uploading and unloading in different environment.

货号		规格	
铝青铜合金	铍青铜合金	L(mm)	B(mm)
AL2028-1002	BE2028-1002	1410	280

防爆(塑把)三号煤锹

Dust Pan with plastic D-handle



● 表面处理颜色为材质自然色或局部静电喷涂处理, 不同材质的锹系列具有它的特殊专业性, 各用于不同的环境、场所挖掘、清淤、装卸, 更便捷。
The surface treatment of natural color and partially electrostatic spraying are available, shovels of different materials have its special professionalism, can be applied for digging, removing silt, uploading and unloading in different environment, more convenient.

货号		规格	
铝青铜合金	铍青铜合金	L(mm)	B(mm)
AL2029-1002	BE2029-1002	1030	245

防爆(铜箍)三号煤锹

Dust Pan with bronze hoop



● 表面处理颜色为材质自然色或局部静电喷涂处理, 不同材质的锹系列具有它的特殊专业性, 各用于不同的环境、场所挖掘、清淤、装卸, 更便捷。
The surface treatment of natural color and partially electrostatic spraying are available, shovels of different materials have its special professionalism, can be applied for digging, removing silt, uploading and unloading in different environment, more convenient.

货号		规格	
铝青铜合金	铍青铜合金	L(mm)	B(mm)
AL2030-1002	BE2030-1002	1390	245

防爆(防滑胶把)三号煤锹

Dust Pan with anti-skid sleeve



● 表面处理颜色为材质自然色或局部静电喷涂处理, 不同材质的锹系列具有它的特殊专业性, 各用于不同的环境、场所挖掘、清淤、装卸。
The surface treatment of natural color and partially electrostatic spraying are available, shovels of different materials have its special professionalism, can be applied for digging, removing silt, uploading and unloading in different environment.

货号		规格	
铝青铜合金	铍青铜合金	L(mm)	B(mm)
AL2031-1002	BE2031-1002	1410	245

防爆(塑把)平裤锁箍掘锹

Edging Spade with plastic D-handle



● 表面处理颜色为材质自然色或局部静电喷涂处理, 不同材质的锹系列具有它的特殊专业性, 连接牢固, 用于不同的环境、场所挖掘。
The surface treatment of natural color and partially electrostatic spraying are available, shovels of different materials have its special professionalism. The connection of handle and shovels are durable, and they can be used for digging in different environment.

货号		规格	
铝青铜合金	铍青铜合金	L(mm)	B(mm)
AL2032-1002	BE2032-1002	970	195

防爆(铜箍)平裤锁箍掘锹

Edging Spade with bronze hoop



● 表面处理颜色为材质自然色或局部静电喷涂处理, 不同材质的锹系列具有它的特殊专业性, 连接牢固, 用于不同的环境、场所挖掘。
The surface treatment of natural color and partially electrostatic spraying are available, shovels of different materials have its special professionalism. The connection of handle and shovels are durable, and they can be used for digging in different environment.

货号		规格	
铝青铜合金	铍青铜合金	L(mm)	B(mm)
AL2033-1002	BE2033-1002	1200	195

防爆工具系列
NON-SPARKING TOOLS

防爆工具系列
NON-SPARKING TOOLS

防爆(防滑胶把)平裤锁箍深掘锹

Edging Spade with anti-skid sleeve



● 表面处理颜色为材质自然色或局部静电喷涂处理, 不同材质的锹系列具有它的特殊专业性, 连接牢固, 用于不同的环境、场所挖掘。
The surface treatment of natural color and partially electrostatic spraying are available, shovels of different materials have its special professionalism. The connection of handle and shovels are durable, and they can be used for digging in different environment.

货号		规格	
铝青铜合金	铍青铜合金	L(mm)	B(mm)
AL2034-1002	BE2034-1002	1220	195

防爆(塑把)平裤锁箍深掘锹

Deep Edging Spade with plastic D-handle



● 表面处理颜色为材质自然色或局部静电喷涂处理, 不同材质的锹系列具有它的特殊专业性, 连接牢固, 用于不同的环境、场所挖掘。
The surface treatment of natural color and partially electrostatic spraying are available, shovels of different materials have its special professionalism. The connection of handle and shovels are durable, and they can be used for digging in different environment.

货号		规格	
铝青铜合金	铍青铜合金	L(mm)	B(mm)
AL2035-1002	BE2035-1002	1030	180

防爆(铜箍)平裤锁箍深掘锹

Deep Edging Spade with bronze hoop



● 表面处理颜色为材质自然色或局部静电喷涂处理, 不同材质的锹系列具有它的特殊专业性, 连接牢固, 用于不同的环境、场所挖掘。
The surface treatment of natural color and partially electrostatic spraying are available, shovels of different materials have its special professionalism. The connection of handle and shovels are durable, and they can be used for digging in different environment.

货号		规格	
铝青铜合金	铍青铜合金	L(mm)	B(mm)
AL2036-1002	BE2036-1002	1200	180

防爆(防滑胶把)平裤锁箍深掘锹

Deep Edging Spade with anti-skid sleeve



● 表面处理颜色为材质自然色或局部静电喷涂处理, 不同材质的锹系列具有它的特殊专业性, 连接牢固, 用于不同的环境、场所挖掘。
The surface treatment of natural color and partially electrostatic spraying are available, shovels of different materials have its special professionalism. The connection of handle and shovels are durable, and they can be used for digging in different environment.

货号		规格	
铝青铜合金	铍青铜合金	L(mm)	B(mm)
AL2037-1002	BE2037-1002	1220	180

防爆便携军锹

Shovel, Military



● 表面处理颜色为材质自然色或局部静电喷涂处理, 不同材质的锹系列具有它的特殊专业性, 各用于不同的环境、场所挖掘、开凿多功能便携式军锹。
The surface treatment of natural color and partially electrostatic spraying are available, shovels of different materials have its special professionalism. This type of portable military shovels is multi-functional, and can be applied for digging and cutting in different environment.

货号		规格	
铝青铜合金	铍青铜合金	L(mm)	B(mm)
AL2038-1002	BE2038-1002	630	170

防爆便携小军锹

Shovel, Military (Mini type)



● 表面处理颜色为材质自然色或局部静电喷涂处理, 不同材质的锹系列具有它的特殊专业性, 各用于不同的环境、场所挖掘、开凿多功能便携式军锹。
The surface treatment of natural color and partially electrostatic spraying are available, shovels of different materials have its special professionalism. This type of portable military shovels is multi-functional, and can be applied for digging and cutting in different environment.

货号		规格	
铝青铜合金	铍青铜合金	L(mm)	B(mm)
AL2039-1002	BE2039-1002	550	130

防爆便携多用军锹

Shovel, Military (Multi-function)



● 表面处理颜色为材质自然色或局部静电喷涂处理, 不同材质的锹系列具有它的特殊专业性, 各用于不同的环境、场所挖掘、开凿多功能便携式军锹。
The surface treatment of natural color and partially electrostatic spraying are available, shovels of different materials have its special professionalism. This type of portable military shovels is multi-functional, and can be applied for digging and cutting in different environment.

货号		规格	
铝青铜合金	铍青铜合金	L(mm)	B(mm)
AL2040-1002	BE2040-1002	580	150

防爆两用锹

Folding Shovel



● 表面处理颜色为材质自然色或局部静电喷涂处理, 不同材质的锹系列具有它的特殊专业性, 连接牢固, 用于不同的环境、场所挖掘。
The surface treatment of natural color and partially electrostatic spraying are available, shovels of different materials have its special professionalism. The connection of handle and shovels are durable, and they can be used for digging in different environment.

货号		规格	
铝青铜合金	铍青铜合金	L(mm)	B(mm)
AL2041-1002	BE2041-1002	570	170

防爆刀子

Knife, Common

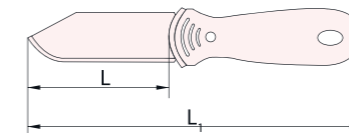

● 在易燃易爆场所, 割制电线绝缘层、绳索等。
Cut electric wire insulation and rope in inflammable and explosive place.

货号		规格		重量(g)	
铝青铜合金	铍青铜合金	L(mm)	L ₁ (mm)	铝青铜合金	铍青铜合金
AL202A-1002	BE202A-1002	90	203	110	95

防爆塑柄削皮刀

Knife, Common

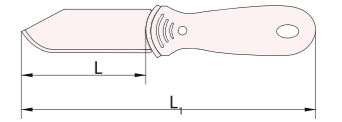

● 在易燃易爆场所, 割制电线绝缘层、绳索等。
Cut electric wire insulation and rope in inflammable and explosive place.

货号		规格		重量(g)	
铝青铜合金	铍青铜合金	L(mm)	L ₁ (mm)	铝青铜合金	铍青铜合金
AL202B-1002	BE202B-1002	80	193	105	90
AL202B-1004	BE202B-1004	137	250	125	105

防爆塑柄泥子刀

Knife, Putty

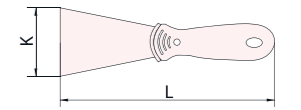

● 易燃易爆场所用于刮涂腻子油灰、除锈等。
Used for scraping and descaling in inflammable and explosive place.

货号		规格		重量(g)	
铝青铜合金	铍青铜合金	k(mm)	L(mm)	铝青铜合金	铍青铜合金
AL203A-1002	BE203A-1002	25	203	95	85
AL203A-1004	BE203A-1004	40	203	105	90
AL203A-1006	BE203A-1006	50	203	110	95
AL203A-1008	BE203A-1008	65	203	120	100

防爆塑柄泥子刀

Knife, Putty

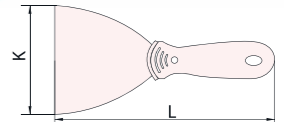

● 易燃易爆场所用于刮涂腻子油灰、除锈等。
Used for scraping and descaling in inflammable and explosive place.

货号		规格		重量(g)	
铝青铜合金	铍青铜合金	k(mm)	L(mm)	铝青铜合金	铍青铜合金
AL203B-1002	BE203B-1002	75	203	130	110
AL203B-1004	BE203B-1004	100	203	150	125
AL203B-1006	BE203B-1006	150	203	310	280

防爆工具系列
NON-SPARKING TOOLS

防爆工具系列
NON-SPARKING TOOLS

防爆圆弧抹刀

Spatula

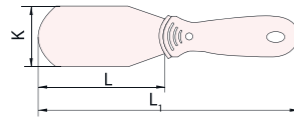

- 易燃易爆场所用于刮涂腻子油灰、除锈等。
Used for scraping and descaling in inflammable and explosive place.

货号		规格			重量(g)	
铝青铜合金	铍青铜合金	K(mm)	L(mm)	L ₁ (mm)	铝青铜合金	铍青铜合金
AL204A-1002	BE204A-1002	30	90	203	80	85
AL204A-1004	BE204A-1004	50	105	218	110	115
AL204A-1006	BE204A-1006	90	120	233	145	160

防爆电工刀

Electrician Knife

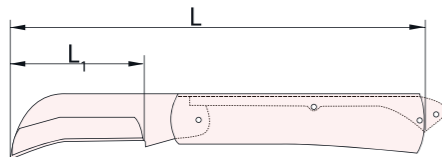

- 在易燃易爆场所，割削电线绝缘层、绳索等。
Cut electric wire insulation and rope in inflammable and explosive place.

货号		规格		重量(g)	
铝青铜合金	铍青铜合金	L ₁ (mm)	L(mm)	铝青铜合金	铍青铜合金
AL204B-1002	BE204B-1002	60	195	185	210

防爆长柄圆弧抹刀

Spatula

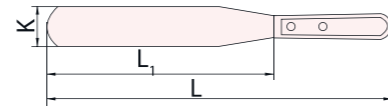

- 用于清理特殊部位油污、除锈等。
Used for scraping and descaling in inflammable and explosive place.

货号		规格			重量(g)	
铝青铜合金	铍青铜合金	K(mm)	L ₁ (mm)	L ₂ (mm)	铝青铜合金	铍青铜合金
AL204D-1002	BE204D-1002	40	350	230	110	120

防爆加套刀子

Knife

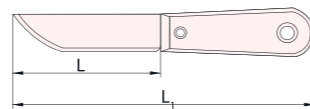

- 在易燃易爆场所，割削电线绝缘层、绳索等。
Cut electric wire insulation and rope in inflammable and explosive place.

货号		规格		重量(g)	
铝青铜合金	铍青铜合金	L ₁ (mm)	L(mm)	铝青铜合金	铍青铜合金
AL204F-1002	BE204F-1002	110	216	120	90

防爆刀子

Knife

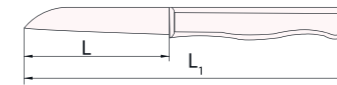

- 在易燃易爆场所，割削电线绝缘层、绳索等。
Cut electric wire insulation and rope in inflammable and explosive place.

货号		规格		重量(g)
铝青铜合金	铍青铜合金	L ₁ (mm)	L ₂ (mm)	铍青铜合金
BE204G-1002		180	75	90

防爆刮丝刀

Knife, Wire Stripping and Scraping

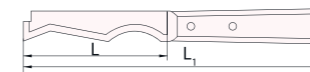

- 在易燃易爆场所，割削电线绝缘层、绳索等。
Cut electric wire insulation and rope in inflammable and explosive place.

货号		规格		重量(g)	
铝青铜合金	铍青铜合金	L ₁ (mm)	L ₂ (mm)	铝青铜合金	铍青铜合金
AL204H-1002	BE204H-1002	230	120	110	120

防爆木柄除锈刀

Scrapers

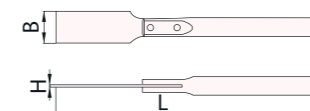

- 在易燃易爆场所清除锈迹，污物。刀片薄，柄长，轻松作业。
Used to remove dirt and rust in inflammable and explosive place, thin blade, long handle, easy to use.

货号		规格			重量(g)	
铝青铜合金	铍青铜合金	L(mm)	B(mm)	H(mm)	铝青铜合金	铍青铜合金
AL205-1002	BE205-1002	902	50	2	625	683

防爆塑柄除锈刀

Scraper

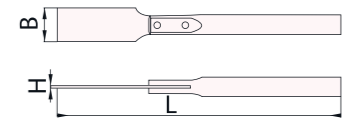

- 在易燃易爆场所清除锈迹，污物。刀片薄，柄长，轻松作业。
Used to remove dirt and rust in inflammable and explosive place, thin blade, long handle, easy to use.

货号		规格			重量(g)	
铝青铜合金	铍青铜合金	L(mm)	B(mm)	H(mm)	铝青铜合金	铍青铜合金
AL205A-1002	BE205A-1002	902	50	2	625	683

防爆除锈刀

Scraper

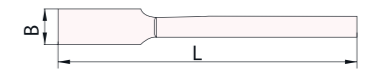

- 在易燃易爆场所清除锈迹，污物。刀片薄，柄长，轻松作业。
Used to remove dirt and rust in inflammable and explosive place, thin blade, long handle, easy to use.

货号		规格		重量(g)	
铝青铜合金	铍青铜合金	L(mm)	B(mm)	铝青铜合金	铍青铜合金
AL205B-1002	BE205B-1002	1190	50	2550	2800
AL205B-1004	BE205B-1004	1205	75	2850	3130
AL205B-1006	BE205B-1006	1220	100	3000	3300

防爆除锈刀

Scraper, Flat



- 在易燃易爆场所清除锈迹，污物。刀片薄，柄长，轻松作业。
Used to remove dirt and rust in inflammable and explosive place, thin blade, long handle, easy to use.

货号		规格			重量(g)	
铝青铜合金	铍青铜合金	L(mm)	B(mm)	L ₁ (mm)	铝青铜合金	铍青铜合金
AL206-1002	BE206-1002	200	30	325	300	330
AL206-1004	BE206-1004	300	30	430	440	480
AL206-1006	BE206-1006	350	35	490	580	640
AL206-1008	BE206-1008	350	50	490	910	1020
AL206-1010	BE206-1010	400	60	460	1330	1520

防爆两头扁刮刀

Scraper, Deck



- 在易燃易爆场所用于修整与刮光用的一种除锈刀具。
Descaling scraper for trimming and scraping in inflammable and explosive place.

货号		规格		重量(g)	
铝青铜合金	铍青铜合金	L(mm)	B(mm)	铝青铜合金	铍青铜合金
AL207-1002	BE207-1002	250	39	255	285
AL207-1004	BE207-1004	300	45	335	380
AL207-1006	BE207-1006	350	55	507	555
AL207-1008	BE207-1008	400	50	700	775
AL207-1010	BE207-1010	650	56	1290	1405
AL207-1012	BE207-1012	750	58	1380	1540

货号		规格		重量(g)	
铝青铜合金	铍青铜合金	L(inch)	B(inch)	铝青铜合金	铍青铜合金
AL207A-1002	BE207A-1002	12	2	425	460

防爆两头扁刮刀

Scraper, Deck

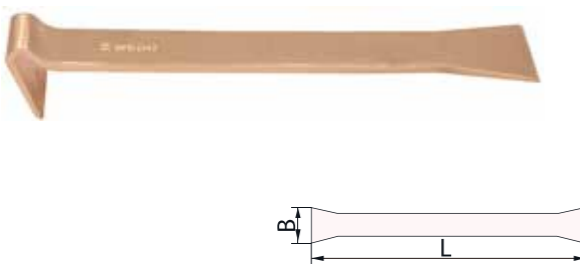

- 在易燃易爆场所用于修整与刮光用的一种除锈刀具。
Descaling scraper for trimming and scraping in inflammable and explosive place.

货号		规格		重量(g)	
铝青铜合金	铍青铜合金	L(mm)	B(mm)	铝青铜合金	铍青铜合金
AL208-1002	BE208-1002	270	40	338	371

防爆刮刀

Scraper, Deck

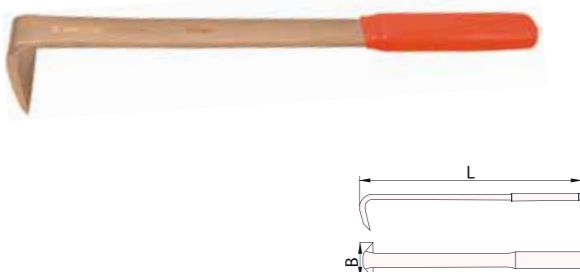

- 在易燃易爆场所用于修整与刮光用的一种除锈刀具。
Descaling scraper for trimming and scraping in inflammable and explosive place.

货号		规格		重量(g)	
铝青铜合金	铍青铜合金	L(mm)	B(mm)	铝青铜合金	铍青铜合金
AL209-1002	BE209-1002	300	48	391	432

防爆刮刀

Scraper, Deck

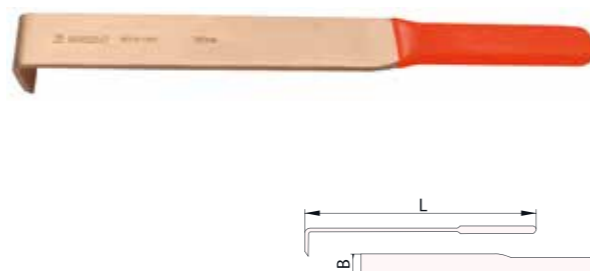

- 在易燃易爆场所用于修整与刮光用的一种除锈刀具。
Descaling scraper for trimming and scraping in inflammable and explosive place.

货号		规格		重量(g)	
铝青铜合金	铍青铜合金	L(mm)	B(mm)	铝青铜合金	铍青铜合金
AL210-1002	BE210-1002	380	38	720	821

防爆除锈铲

Scraper, Spray Booth

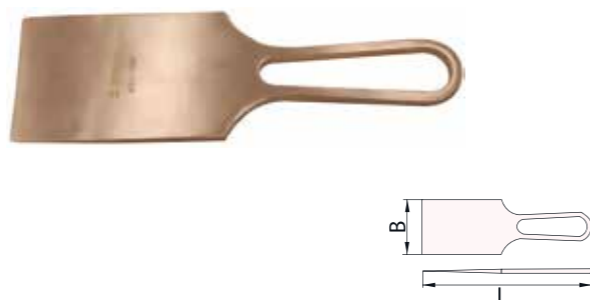

- 用于清除锈迹, 污物。铲和手柄一体, 近距离除锈, 便于用力。
Used to remove dirt and rust in close range, integrated scraper and handle, easy to use.

货号		规格		重量(g)	
铝青铜合金	铍青铜合金	L(mm)	B(mm)	铝青铜合金	铍青铜合金
AL211-1002	BE211-1002	235	76	358	392

防爆装柄除锈铲

Scraper

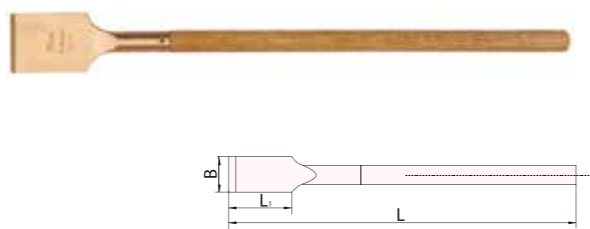

- 模锻、密度高, 刃口更锋利, 除锈除污省力。
One-time die-forged, high density, sharper blade, easy to remove dirt and rust.

货号		规格			重量(g)	
铝青铜合金	铍青铜合金	L(mm)	L _i (mm)	B(mm)	铝青铜合金	铍青铜合金
AL212-1002	BE212-1002	690	90	50	520	550
AL212-1004	BE212-1004	705	100	75	700	750
AL212-1006	BE212-1006	720	115	100	800	850
AL212-1008	BE212-1008	765	150	150	1300	1400

防爆方头除锈刀

Scraper, Hand Style



- 易于易燃易爆场所, 适合近距离除锈除污。
Used to remove dirt and rust in close range in inflammable and explosive place.

货号		规格			重量(g)	
铝青铜合金	铍青铜合金	L(mm)	L _i (mm)	B(mm)	铝青铜合金	铍青铜合金
AL212A-1002	BE212A-1002	480	95	95	540	600

防爆圆弧除锈刀

Scraper, Rust

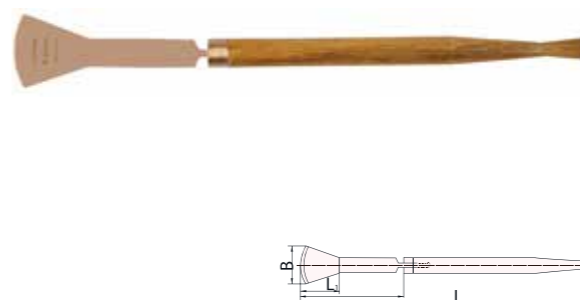

- 易用清除圆弧面的锈迹和污渍。
Used to clean irregularly arc surface.

货号		规格			重量(g)	
铝青铜合金	铍青铜合金	L(mm)	L _i (mm)	B(mm)	铝青铜合金	铍青铜合金
AL212B-1002	BE212B-1002	600	75	75	620	700

防爆弧形除锈铲

Scraper, Arched

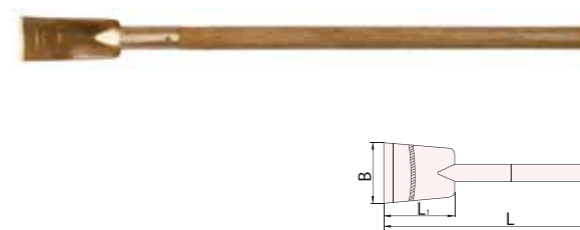

- 可根据使用部位, 选择最佳圆弧直径, 清除锈迹。
Used to clean irregularly arc surface, various sizes are available depending on the application area.

货号		规格			重量(g)	
铝青铜合金	铍青铜合金	L(mm)	L _i (mm)	B(mm)	铝青铜合金	铍青铜合金
AL213-1002	BE213-1002	690	120	50	600	650
AL213-1004	BE213-1004	710	120	100	830	925
AL213-1006	BE213-1006	720	120	150	980	1080

防爆地板刮刀

Scraper, Floor



- 宽大刀幅, 便于清除地板上的脏污。
With wide blade, convenient to remove dirt on the floor.

货号		规格			重量(g)	
铝青铜合金	铍青铜合金	L(mm)	L _i (mm)	B(mm)	铝青铜合金	铍青铜合金
AL213A-1002	BE213A-1002	460	170	150	1000	1150

防爆开油漆桶刀

Opener Carbide Drum

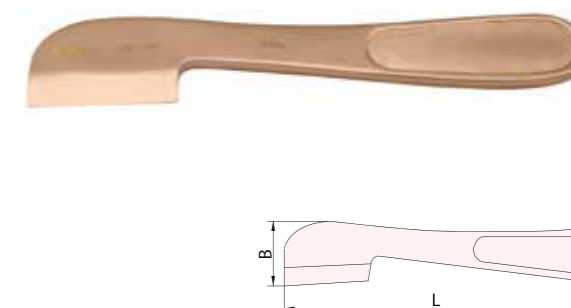

- 与钳工锤配合使用, 开启油桶。
Used to open the oil drum.

货号		规格			重量(g)	
铝青铜合金	铍青铜合金	L(mm)	B(mm)	铝青铜合金	铍青铜合金	
AL214-1002	BE214-1002	280	53	358	392	

防爆瓦刀

Scraper, Tile Cleaver

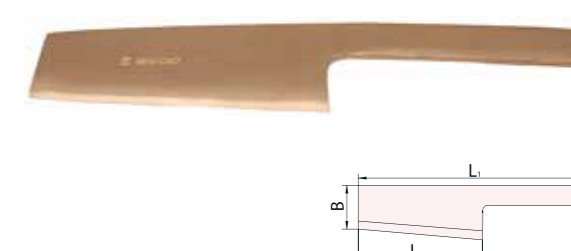

- 易燃易爆场所用于斩断或修剪砖瓦、填敷泥灰等。
Used for bricklaying.

货号		规格			重量(g)	
铝青铜合金	铍青铜合金	L(mm)	L _i (mm)	B(mm)	铝青铜合金	铍青铜合金
AL215-1002	BE215-1002	180	350	55	550	610

防爆剪刀
Tinner's Snip Plate Shear

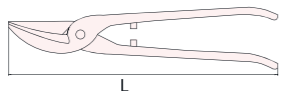

- 圆弧刃口，特别适合切割线状物体。
Arc shape cutting edge, especially suitable for cutting thread shape object.

货号		规格		重量(g)	
铝青铜合金	铍青铜合金	L(mm)		铝青铜合金	铍青铜合金
AL244B-1002	BE244B-1002	100		70	80

防爆夹钳
Shears

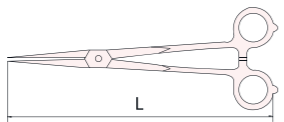

- 用于夹持细小物品。
Used to clamp or hold small objects.

货号		规格		重量(g)	
铝青铜合金	铍青铜合金	L(mm)		铝青铜合金	铍青铜合金
AL244C-1002	BE244C-1002	200		410	488

防爆迷你斜口钳
Mini Pliers, Diagonal Cutting



- 易燃易爆场所，锥形或修整金属工件的圆弧槽及内孔。
In combustible and explosive area.
File or trim the circular arc groove and inner bore of metal workpiece.

货号		规格		重量(g)	
铝青铜合金	铍青铜合金	Φ(mm)	L(mm)	铝青铜合金	铍青铜合金
AL248B-1002	BE248B-1002	5	125	50	60

防爆煤气管钳子
Gas Pliers

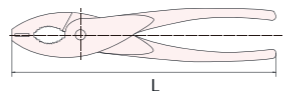

- 用于夹持圆柱形金属零件，维修、检修煤气管道。
Used to clamp or hold cylinder shape metallic parts, maintain or inspect gas piping.

货号		规格		重量(g)	
铝青铜合金	铍青铜合金	L(mm)		铝青铜合金	铍青铜合金
AL245A-1002	BE245A-1002	200		315	350

防爆德式鲤鱼钳
Pliers, Adjustable Combination(Germany Type)

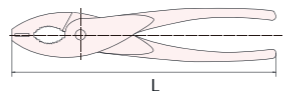

- 用于夹持扁形或圆柱形金属零件，其钳口的开口宽度有两档调节位置，可以夹持尺寸较大的零件，刃口可切断金属丝，亦可代替扳手装卸螺栓、螺母。
Serrated teeth with slip joint.

货号		规格		重量(g)	
铝青铜合金	铍青铜合金	Size(inch)	L(mm)	铝青铜合金	铍青铜合金
AL245B-1002	BE245B-1002	6	150	165	190
AL245B-1004	BE245B-1004	8	200	270	310

防爆鲤鱼钳
Pliers, Adjustable Combination

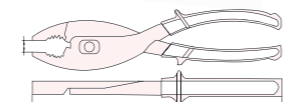

- 用于夹持扁形或圆柱形金属零件，其钳口的开口宽度有两档调节位置，可以夹持尺寸较大的零件，刃口可以切割金属丝，亦可代替扳手装卸螺栓、螺母。
Used to clamp flat or cylinder metal parts, two shifts of pincer mouth, clamp parts of large size, the blade can cut metal wire, and it can be used as wrench to loosen and tighten bolts and nuts.

货号		规格		重量(g)	
铝青铜合金	铍青铜合金	K(mm)	L(mm)	铝青铜合金	铍青铜合金
AL245-1002	BE245-1002	8	150	165	175
AL245-1004	BE245-1004	13	200	330	355

防爆克丝钳
Pliers, Lineman

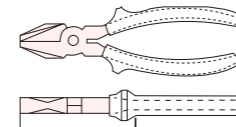

- 用于夹持或弯折薄片，剪断导线和金属丝。
Clamp or bend sheet, cut wires.

货号		规格		重量(g)	
铝青铜合金	铍青铜合金	B(mm)	L(mm)	铝青铜合金	铍青铜合金
AL246-1002	BE246-1002	6	150	230	250
AL246-1004	BE246-1004	7	175	330	355
AL246-1006	BE246-1006	8	200	375	410
AL246-1008	BE246-1008	10	250	500	550

防爆斜口钳
Pliers, Diagonal Cutting

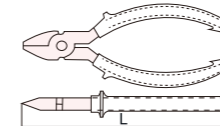

- 用于切断金属丝，平口斜嘴适宜在凹下的工作空间中使用时，为电线安装电器装配和维修工作中常用的工具。
Cut metal wires, flat end and diagonal mouth is suitable for concave work space. A Common tool for electric wire installation, electric facilities installation and maintenance.

货号		规格		重量(g)	
铝青铜合金	铍青铜合金	L(inch)	L(mm)	铝青铜合金	铍青铜合金
AL248-1002	BE248-1002	6	150	200	220
AL248-1004	BE248-1004	8	200	365	410

防爆鸭嘴钳
Pliers, Flat Nose

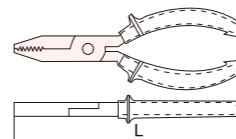

货号		规格		重量(g)	
铝青铜合金	铍青铜合金	L(inch)	L(mm)	铝青铜合金	铍青铜合金
AL250-1002	BE250-1002	6	150	185	200
AL250-1004	BE250-1004	8	200	257	281

防爆A型尖嘴钳
Pliers, Snipe Nose

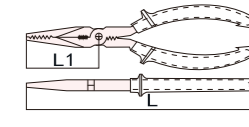

货号		规格		重量(g)	
铝青铜合金	铍青铜合金	L(inch)	L(mm)	铝青铜合金	铍青铜合金
AL254-1002	BE254-1002	6	150	170	190
AL254-1004	BE254-1004	8	200	300	335

防爆圆嘴钳/Pliers, Round Nose
Pliers, Round Nose

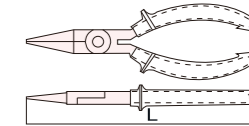

货号		规格		重量(g)	
铝青铜合金	铍青铜合金	L(inch)	L(mm)	铝青铜合金	铍青铜合金
AL255-1002	BE255-1002	6	150	175	190

防爆弯嘴钳
Pliers, Round 45° Degree Bent

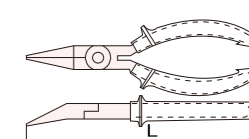

货号		规格		重量(g)	
铝青铜合金	铍青铜合金	L(inch)	L(mm)	铝青铜合金	铍青铜合金
AL255A-1002	BE255A-1002	6	150	170	190

防爆美式斜口钳
Pliers, Diagonal Cutting (American Type)

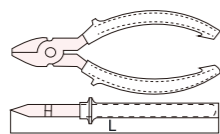

• 用于切断金属丝，平口斜嘴适宜在凹下的工作空间中使
Used for cutting metal wires, with diagonal nose, easy to use in concave work place.

货号		规格		重量(g)	
铝青铜合金	铍青铜合金	L(inch)	L(mm)	铝青铜合金	铍青铜合金
AL248C-1002	BE248C-1002	6	150	185	215
AL248C-1004	BE248C-1004	8	190	330	385

防爆胡桃钳
Pincers



• 主要用于起钉，也可剪切钉子和金属丝。
Used to remove nails, or cut nails and other metal wires.

货号		规格		重量(g)	
铝青铜合金	铍青铜合金	L(inch)	L(mm)	铝青铜合金	铍青铜合金
AL249-1002	BE249-1002	8	200	300	325

防爆顶切钳
Pincers



• 剪切金属丝常用于机械、电器的装配及维修。
Used to cut metal wire in the installation and maintenance of device and electric facilities.

货号		规格		重量(g)	
铝青铜合金	铍青铜合金	L(inch)	L(mm)	铝青铜合金	铍青铜合金
AL249A-1002	BE249A-1002	7	175	225	250

防爆E型顶切
Pincers



• 易燃易爆场所，锉削或修整金属工件的平面、狭窄的缝隙、凹槽、V型槽。
In combustible and explosive area, file or trim the plane, narrow apertures, groove and V-groove of metal workpiece.

货号		规格		重量(g)	
铝青铜合金	铍青铜合金	L(inch)	L(mm)	铝青铜合金	铍青铜合金
AL249B-1002	BE249B-1002	6	150	175	190

防爆叠置式水泵钳
Pliers, Groove Joint

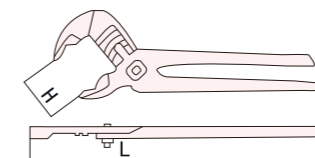

货号		规格			重量(g)	
铝青铜合金	铍青铜合金	L(inch)	L(mm)	K _{max} (mm)	铝青铜合金	铍青铜合金
AL251-1002	BE251-1002	6	150	25	160	180
AL251-1004	BE251-1004	10	250	45	370	425
AL251-1006	BE251-1006	12	300	55	600	670
AL251-1008	BE251-1008	14	350	55	770	850

防爆套入式水泵钳
Pliers, Slip Joint

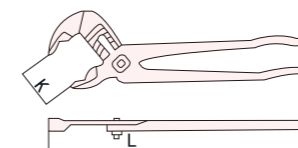

货号		规格			重量(g)	
铝青铜合金	铍青铜合金	L(inch)	L(mm)	K _{max} (mm)	铝青铜合金	铍青铜合金
AL252-1002	BE252-1002	10	250	32	335	365

防爆新式水泵钳
Pliers, Water Pump

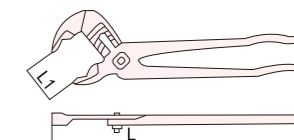

货号		规格			重量(g)	
铝青铜合金	铍青铜合金	L(inch)	L(mm)	K _{max} (mm)	铝青铜合金	铍青铜合金
AL252A-1002	BE252A-1002	10	250	32	310	325
AL252A-1004	BE252A-1004	12	300	52	610	665

防爆德式套入式水泵钳
Pliers, Slip Joint



• 用于夹持旋拧扁形或圆柱形金属零件，其特点钳口的开口宽度可多档调节位置。
Used for clamping and screwing flat or cylinder metal parts, with multi-position selective switch for adjusting the jaw opening width.

货号		规格			重量(g)	
铝青铜合金	铍青铜合金	L(mm)	K _{max} (mm)	铝青铜合金	铍青铜合金	
AL252B-1002	BE252B-1002	165	25	220	250	
AL252B-1004	BE252B-1004	250	35	435	500	
AL252B-1006	BE252B-1006	300	38	700	780	

防爆内挡圈钳
Pliers, Snap Ring-Internal



• 用来砸击、夯实水泥、堵缝，也可以击打碎水泥块。
Used to smash or tamp concrete, seam, or break concrete block.

货号		规格		重量(g)	
铝青铜合金	铍青铜合金	L(inch)	L(mm)	铝青铜合金	铍青铜合金
AL256-1002	BE256-1002	8	200	265	290
AL256-1004	BE256-1004	10	250	380	415

防爆外挡圈钳
Pliers, Snap Ring-External

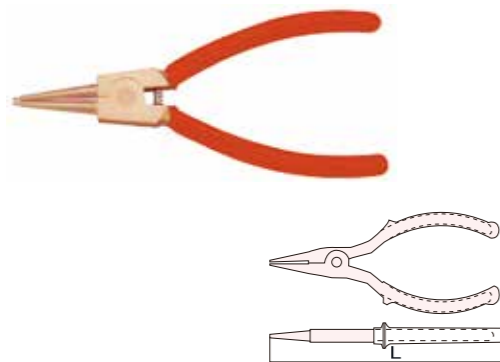

• 用来砸击、夯实水泥、堵缝，也可以击打碎水泥块。
Used to smash or tamp concrete, seam, or break concrete block.

货号		规格		重量(g)	
铝青铜合金	铍青铜合金	L(inch)	L(mm)	铝青铜合金	铍青铜合金
AL257-1002	BE257-1002	8	200	265	290
AL257-1004	BE257-1004	10	250	380	415

防爆断线钳
Bolt Chipper

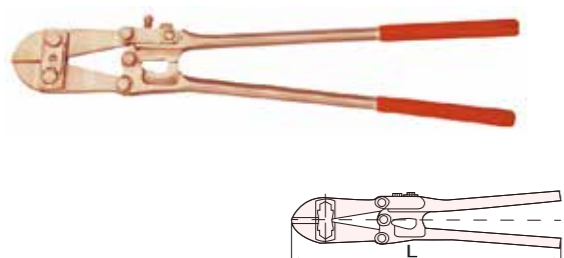

货号		规格		重量(g)	
铝青铜合金	铍青铜合金	L(mm)	D(mm)	铝青铜合金	铍青铜合金
AL257A-1002	BE257A-1002	600	6	3070	3350
AL257A-1004	BE257A-1004	900	8	8400	9250

防爆剥线压线断线钳
Crimping Tool, Insulated Cable Connectors

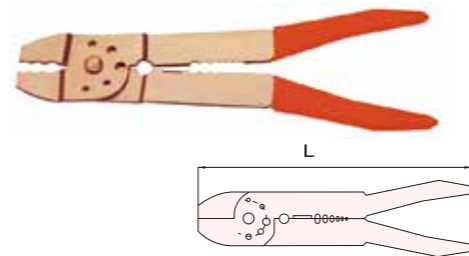

货号		规格		重量(g)	
铝青铜合金	铍青铜合金	L(inch)	L(mm)	铝青铜合金	铍青铜合金
AL257B-1002	BE257B-1002	8	200	205	225

防爆剥线钳
Wire Stripping Pliers

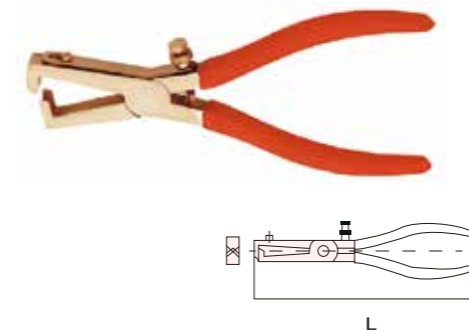

货号		规格		重量(g)	
铝青铜合金	铍青铜合金	L(mm)		铝青铜合金	铍青铜合金
AL257C-1002	BE257C-1002	170		205	225

防爆大力钳
Locking Pliers



货号		规格			重量(g)	
铝青铜合金	铍青铜合金	Size(mm)	L(mm)	D(mm)	铝青铜合金	铍青铜合金
AL257D-1002	BE257D-1002	10	225	40	455	480

防爆剥线钳
Wire Stripper



货号		规格		重量(g)	
铝青铜合金	铍青铜合金	L(inch)	L(mm)	铝青铜合金	铍青铜合金
AL257E-1002	BE257E-1002	6	160	125	110

防爆多用钳子
Stocker Plier



货号		规格		重量(g)	
铝青铜合金	铍青铜合金	L(inch)	L(mm)	铝青铜合金	铍青铜合金
AL257F-1002	BE257F-1002	7	180	200	220

防爆镊子
Tweezers, Neat Tips



货号		规格		重量(g)	
铝青铜合金	铍青铜合金	L(mm)		铝青铜合金	铍青铜合金
AL258-1002	BE258-1002	150		30	25
AL258-1004	BE258-1004	200		50	40

防爆镊子
Tweezers, Flat Nose

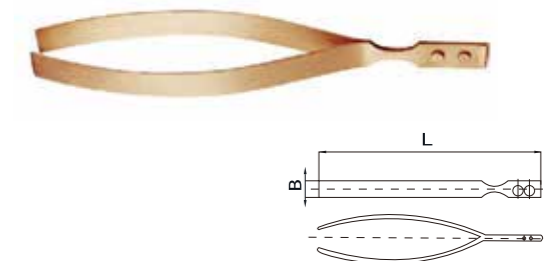

货号		规格		重量(g)	
铝青铜合金	铍青铜合金	L(mm)	B(mm)	铝青铜合金	铍青铜合金
AL258A-1002	BE258A-1002	100	8	30	25
AL258A-1004	BE258A-1004	200	15	65	55

防爆S型一字螺丝刀
Slotted Offset Screwdriver

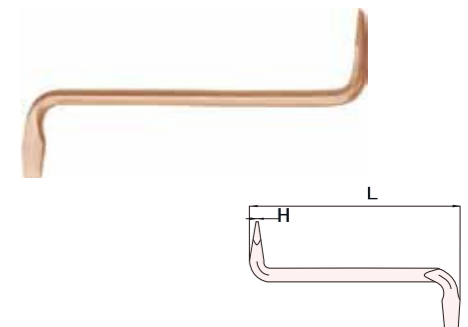

货号		规格			重量(g)	
铝青铜合金	铍青铜合金	L(mm)	H(mm)	K(mm)	铝青铜合金	铍青铜合金
AL259-1002	BE259-1002	72	1.1	6	23	25
AL259-1004	BE259-1004	125	1.2	8	50	55
AL259-1006	BE259-1006	196	1.6	10	124	135

防爆S型十字螺丝刀
Phillips Offset Screwdriver

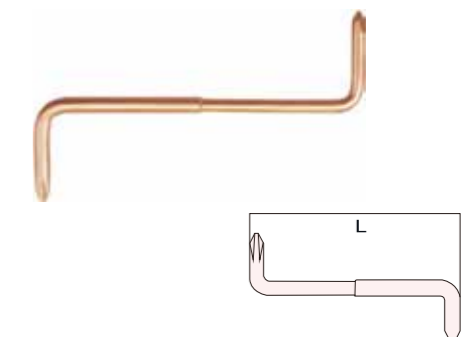

货号		规格		重量(g)	
铝青铜合金	铍青铜合金	L(mm)	Size	铝青铜合金	铍青铜合金
AL259A-1002	BE259A-1002	120	1#*2#	45	50

防爆螺丝刀头
Screwdriver Bits



货号		规格	
铝青铜合金	铍青铜合金	SIZE	
AL264B-S	BE264B-S	①	4.5mm, 6.5mm, 8mm
AL264B-PH	BE264B-PH	⊕	1#, 2#, 3#, 4#
AL264B-PZ	BE264B-PZ	⊖	1#, 2#, 3#, 4#
AL264B-H	BE264B-H	⦿	3mm, 4mm, 5mm, 6mm, 7mm, 10mm
AL264B-T	BE264B-T	⦿	T10, T15, T20, T25, T27, T30, T40

防爆冲击螺丝刀批
Manual Impact Screwdriver Set



货号		规格		重量(g)	
铝青铜合金	铍青铜合金	Size(mm)	PCS	铝青铜合金	铍青铜合金
AL264C ①	BE264C ①	8*70	2	750	825
AL264C ⊕	BE264C ⊕	PH4*70	2		
AL264C ①	BE264C ①	8*30	1		
AL264C ⊕	BE264C ⊕	PH4*30	1		

防爆一字木柄螺丝刀
Slotted Screwdriver



货号		规格					重量(g)	
铝青铜合金	铍青铜合金	L ₁ (inch)	L ₂ (mm)	L ₃ (mm)	H ₁ (mm)	B ₁ (mm)	铝青铜合金	铍青铜合金
AL265-1002	BE265-1002	2	50	150	0.5	3	33	35
AL265-1004	BE265-1004	2	50	150	1	4.5	40	43
AL265-1006	BE265-1006	3	75	175	0.6	3	32	35
AL265-1008	BE265-1008	3	75	175	0.8	4	42	45
AL265-1010	BE265-1010	3	75	175	1	5	65	70
AL265-1012	BE265-1012	4	100	200	0.8	4	42	45
AL265-1014	BE265-1014	4	100	200	1	5	70	75
AL265-1016	BE265-1016	4	100	200	1.1	6	80	85
AL265-1018	BE265-1018	5	125	225	1.1	6	95	100
AL265-1020	BE265-1020	6	150	250	1.1	6	105	110
AL265-1022	BE265-1022	6	150	250	1.2	7	120	125
AL265-1024	BE265-1024	6	150	250	1.2	8	135	140
AL265-1026	BE265-1026	8	200	320	1.2	8	155	165
AL265-1028	BE265-1028	10	250	370	1.6	9	175	185
AL265-1030	BE265-1030	10	250	400	1.8	11	245	260
AL265-1032	BE265-1032	12	300	450	1.6	10	230	245
AL265-1034	BE265-1034	12	300	450	1.8	11	275	290
AL265-1036	BE265-1036	14	350	500	1.8	11	300	320
AL265-1038	BE265-1038	16	400	550	2	12	430	450
AL265-1040	BE265-1040	18	450	600	2.2	13	450	470

防爆十字木柄螺丝刀
Phillips Screwdriver



货号		规格					重量(g)	
铝青铜合金	铍青铜合金	L ₁ (inch)	Size	L ₂ (mm)	L ₃ (mm)	Φ ₁ (mm)	铝青铜合金	铍青铜合金
AL266-1002	BE266-1002	2	0	50	150	3	32	35
AL266-1004	BE266-1004	3	1	75	175	4	63	70
AL266-1006	BE266-1006	4	1	100	200	5	70	75
AL266-1008	BE266-1008	5	2	125	225	6	95	100
AL266-1010	BE266-1010	6	2	150	250	6	105	110
AL266-1012	BE266-1012	8	3	200	320	8	155	165
AL266-1014	BE266-1014	10	3	250	370	8	170	185
AL266-1016	BE266-1016	12	4	300	450	9	230	245
AL266-1018	BE266-1018	14	4	350	500	9	255	270
AL266-1020	BE266-1020	16	4	400	550	9	280	295
AL266-1022	BE266-1022	18	4	450	600	9	300	320

防爆手用穿针
Marking Tool

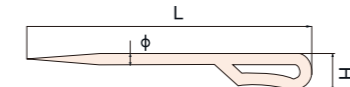
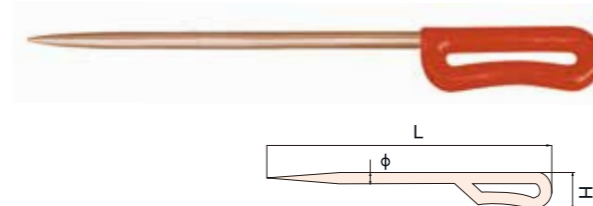

货号		规格			重量(g)	
铝青铜合金	铍青铜合金	L ₁ (mm)	H ₁ (mm)	Φ ₁ (mm)	铝青铜合金	铍青铜合金
AL267-1002	BE267-1002	400	40	12	445	502
AL267-1004	BE267-1004	600	50	16	1036	1152

防爆T型钎子
Marking Tool

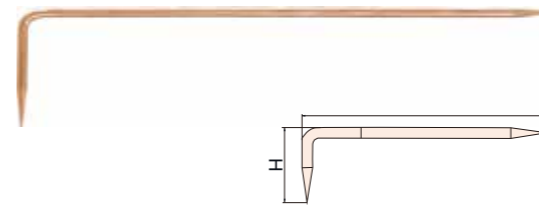

货号		规格			重量(g)	
铝青铜合金	铍青铜合金	L ₁ (mm)	H ₁ (mm)	Φ ₁ (mm)	铝青铜合金	铍青铜合金
AL268-1002	BE268-1002	187	32	4	10	15
AL268-1004	BE268-1004	252	42	4	15	20

防爆锥子
Awl

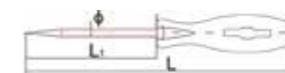

货号		规格			重量(g)		
铝青铜合金	铍青铜合金	L ₁ (inch)	L ₂	Φ ₁ (mm)	L ₃ (mm)	铝青铜合金	铍青铜合金
AL269-1002	BE269-1002	4	100	3	184	45	50

防爆划规
Dividers

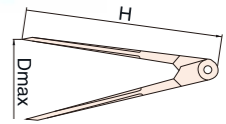
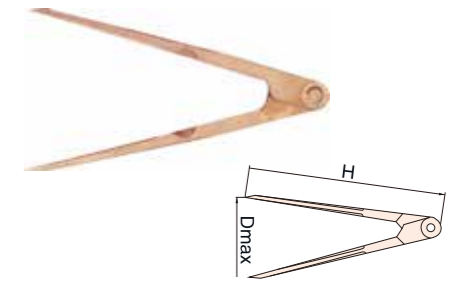

货号		规格		重量(g)	
铝青铜合金	铍青铜合金	D _{max} (inch)	H ₁ (mm)	铝青铜合金	铍青铜合金
AL269A-1002	BE269A-1002	200	200	150	170
AL269A-1004	BE269A-1004	400	400	360	400

防爆锯弓子
Hacksaw Frame

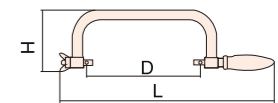

货号		规格			重量(g)	
铝青铜合金	铍青铜合金	L ₁ (mm)	D ₁ (mm)	H ₁ (mm)	铝青铜合金	铍青铜合金
AL270-1002	BE270-1002	500	300	110	590	645

防爆锯弓子
Hacksaw Frame



货号		规格			重量(g)	
铝青铜合金	铍青铜合金	L ₁ (mm)	D ₁ (mm)	H ₁ (mm)	铝青铜合金	铍青铜合金
AL270A-1002	BE270A-1002	470	300	90	650	720

防爆锯条 (50根/盒)

Hacksaw Blade

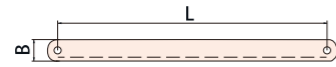

货号	规格		重量(g)
铝青铜合金	L(mm)	B(mm)	铝青铜合金
BE271-1002	300	12	32

防爆鸡尾锯

Hand Saw

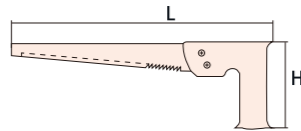

货号	规格		重量(g)		
铝青铜合金	铝青铜合金	L(mm)	H(mm)	铝青铜合金	铝青铜合金
AL272-1002	BE272-1002	370	114	265	125

防爆手板锯

Hand Saw



货号	规格		重量(g)		
铝青铜合金	铝青铜合金	L(mm)	B(mm)	铝青铜合金	铝青铜合金
AL272A-1002	BE272A-1002	700	35	520	555

防爆三爪拔轮器

3 Leg Gear Puller

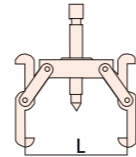

货号		规格	重量(g)	
铝青铜合金	铝青铜合金	L(max)	铝青铜合金	铝青铜合金
AL273-1002	BE273-1002	100	1200	1350
AL273-1004	BE273-1004	150	2500	2800
AL273-1006	BE273-1006	200	5200	5720
AL273-1008	BE273-1008	250	9700	10650

防爆两爪拔轮器

2 Leg Gear Puller

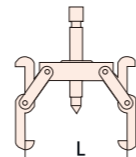

货号		规格	重量(g)	
铝青铜合金	铝青铜合金	L(max)	铝青铜合金	铝青铜合金
AL273A-1002	BE273A-1002	100	1100	1250
AL273A-1004	BE273A-1004	150	2200	2450
AL273A-1006	BE273A-1006	200	4640	5130
AL273A-1008	BE273A-1008	250	8800	9600

防爆液压拔轮器

Hydraulic Gear Puller



货号		规格	重量(g)		
铝青铜合金	铝青铜合金	Safe load(T)	Φ(mm)	铝青铜合金	铝青铜合金
AL273B-5	BE273B-5	5	200	7500	8000
AL273B-10	BE273B-10	10	250	11000	12000
AL273B-20	BE273B-20	20	350	19000	20600

防爆G型夹

Clamp

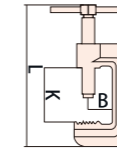

货号		规格			重量(g)	
铝青铜合金	铝青铜合金	L(mm)	K(mm)	B(mm)	铝青铜合金	铝青铜合金
AL274-1002	BE274-1002	210	60	36	1080	1200
AL274-1004	BE274-1004	250	80	36	1270	1400
AL274-1006	BE274-1006	290	100	36	1460	1610
AL274-1008	BE274-1008	340	150	50	1970	2155

防爆G型夹

Clamp

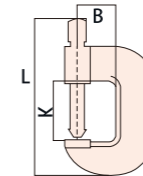

货号		规格			重量(g)	
铝青铜合金	铝青铜合金	L(mm)	K(mm)	B(mm)	铝青铜合金	铝青铜合金
AL274A-1002	BE274A-1002	76	19	19	180	200
AL274A-1004	BE274A-1004	290	115	75	5000	5600
AL274A-1006	BE274A-1006	370	165	90	10000	11100

防爆三齿

Fork, Three Prong

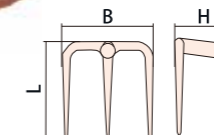

货号		规格			重量(g)	
铝青铜合金	铝青铜合金	L(mm)	B(mm)	H(mm)	铝青铜合金	铝青铜合金
AL275-1002	BE275-1002	185	200	125	1540	1690

防爆四齿叉子

Fork, Four Prong

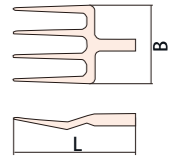

货号		规格		重量(g)	
铝青铜合金	铝青铜合金	L(mm)	B(mm)	铝青铜合金	铝青铜合金
AL276-1002	BE276-1002	327	200	1965	2150

防爆除尘耙子

Cleaning Rust Rake

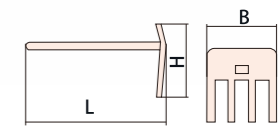

货号		规格			重量(g)	
铝青铜合金	铝青铜合金	L(mm)	H(mm)	B(mm)	铝青铜合金	铝青铜合金
AL277-1002	BE277-1002	350	105	98	950	1050

防爆油漏子

Oil Funnel



货号		规格		重量(g)	
黄铜	铝青铜合金	L(mm)	B(mm)	黄铜	铝青铜合金
BR278-1002	BE278-1002	160	130	260	260
BR278-1004	BE278-1004	160	150	280	280

防爆提油泵
Portable Oil Pump

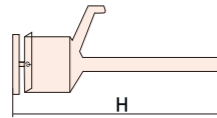

货号		规格		重量(g)	
黄铜	铍青铜合金	Φ(mm)	H(mm)	黄铜	铍青铜合金
BR279-1002	BE279-1002	165	1100	2315	2315

防爆油提子
Oil Dipper

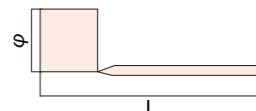

货号		规格		重量(g)	
黄铜	铍青铜合金	Φ(mm)	L(mm)	黄铜	铍青铜合金
BR280-1002	BE280-1002	85	350	163	163

防爆油桶
Bucket



货号		规格		重量(g)	
黄铜	铍青铜合金	Size(L)	H(mm)	黄铜	铍青铜合金
BR280A-1002	BE280A-1002	10	300	1680	1680

防爆长嘴油桶
Bucket



货号		规格		重量(g)	
黄铜	铍青铜合金	Size(L)	H(mm)	黄铜	铍青铜合金
BR280B-1002	BE280B-1002	10	325	1700	1700

防爆长嘴加油壶
Hand Cadger



货号		规格		重量(g)	
黄铜	铍青铜合金	Size(L)	H(mm)	黄铜	铍青铜合金
BR280C-1002	BE280C-1002	2	100	800	800

防爆底部取样器
Bottom Deposit Samplet



货号		规格		重量(g)	
黄铜	铍青铜合金	Size(ml)		黄铜	铍青铜合金
BR280D-1002	BE280D-1002	500		1200	1200

防爆水桶
Bucket



货号		规格		重量(g)	
黄铜	铍青铜合金	Φ(mm)	H(mm)	黄铜	铍青铜合金
BR281-1002	BE281-1002	270	248	1515	1515

防爆加盖水桶
Bucket



货号		规格		重量(g)	
黄铜	铍青铜合金	Size(L)	H(mm)	黄铜	铍青铜合金
BR281A-1002	BE281A-1002	15	280	2000	2000

防爆消防桶
Bucket



货号		规格		重量(g)	
黄铜	铍青铜合金	Size(L)	H(mm)	黄铜	铍青铜合金
BR281B-1002	BE281B-1002	10	250	1200	1200
BR281B-1004	BE281B-1004	15	280	1550	1550

防爆簸箕
Dustpan

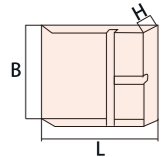

货号		规格			重量(g)	
黄铜	铍青铜合金	L(mm)	B(mm)	H(mm)	黄铜	铍青铜合金
BR282-1002	BE282-1002	150	130	20	130	130
BR282-1004	BE282-1004	200	200	50	335	335
BR282-1006	BE282-1006	270	250	50	635	635

防爆簸箕
Dustpan

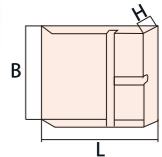

货号		规格			重量(g)	
黄铜	铍青铜合金	L(mm)	B(mm)	H(mm)	黄铜	铍青铜合金
BR282A-1002	BE282A-1002	150	130	20	130	130
BR282A-1004	BE282A-1004	200	200	50	335	335
BR282A-1006	BE282A-1006	270	250	50	635	635

防爆铜舀子
Scoop, Sugar

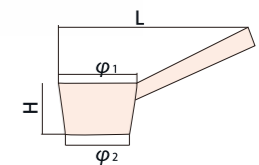

货号		规格				重量(g)	
黄铜	铍青铜合金	L(mm)	H(mm)	Φ1(mm)	Φ2(mm)	黄铜	铍青铜合金
BR283-1002	BE283-1002	350	90	160	135	580	580

防爆料铲
Scoop, Sugar

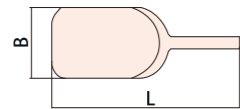

货号		规格		重量(g)	
黄铜	铍青铜合金	B(mm)	L(mm)	黄铜	铍青铜合金
BR283A-1002	BE283A-1002	75	200	200	200
BR283A-1004	BE283A-1004	140	360	645	645

防爆勺子
Scoop

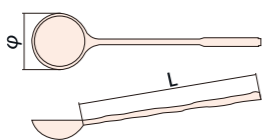

货号		规格		重量(g)	
铝青铜合金	铍青铜合金	Φ(mm)	L(mm)	铝青铜合金	铍青铜合金
AL283B-1002	BE283B-1002	112	500	1100	1220

防爆漏勺
Strainer



货号		规格		重量(g)	
黄铜	铍青铜合金	Φ(mm)	L(mm)	黄铜	铍青铜合金
BR283C-1002	BE283C-1002	300	600	1800	1800

防爆盆
Basin



货号		规格		重量(g)	
黄铜	铍青铜合金	D(mm)	H(mm)	黄铜	铍青铜合金
BR283D-1002	BE283D-1002	400	150	1250	1250

防爆料铲
Scoop, Sugar

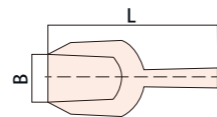

货号		规格		重量(g)	
黄铜	铍青铜合金	B(mm)	L(mm)	黄铜	铍青铜合金
BR283E-1002	BE283E-1002	85	300	200	200
BR283E-1004	BE283E-1004	110	300	230	230

防爆木柄圆头刷
Brush

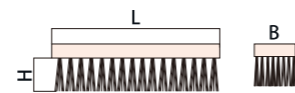

货号		规格			重量(g)	
黄铜	磷铜	L*B(mm)	Rows	H(mm)	黄铜	磷铜
BR284-1002	PH284-1002	205*48	6*16	41	260	260

防爆长柄圆头刷
Brush

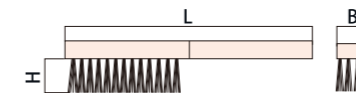

货号		规格			重量(g)	
黄铜	磷铜	L*B(mm)	Rows	H(mm)	黄铜	磷铜
BR285-1002	PH285-1002	290*29	4*16	28	115	115

防爆长柄刷
Brush

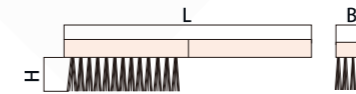

货号		规格			重量(g)	
黄铜	磷铜	L*B(mm)	Rows	H(mm)	黄铜	磷铜
BR285A-1002	PH285A-1002	350*28	4*19	30	150	150

防爆木柄刷
Brush

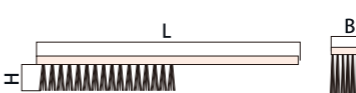

货号		规格			重量(g)	
黄铜	磷铜	L*B(mm)	Rows	H(mm)	黄铜	磷铜
BR286-1002	PH286-1002	215*29	6*15	15	30	30

防爆弯柄刷
Brush, Shoe Handle

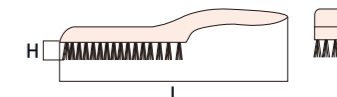

货号		规格			重量(g)	
黄铜	磷铜	L(mm)	Rows	H(mm)	黄铜	磷铜
BR286A-1002	PH286A-1002	255	4*16	30	180	180

防爆清理刷
Brush, Spark-plug Cleaning

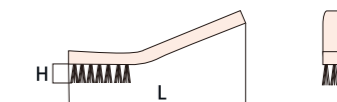

货号		规格			重量(g)	
黄铜	磷铜	L(mm)	Rows	H(mm)	黄铜	磷铜
BR286B-1002	PH286B-1002	196	3*7	13	20	20

防爆板刷
Broom, Round Wire

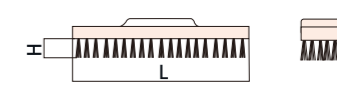

货号		规格			重量(g)	
黄铜	磷铜	L(mm)	Rows	H(mm)	黄铜	磷铜
BR286C-1002	PH286C-1002	310	6*25	55	550	550

防爆硬质板刷
Scrubbing Broom, Round Wire

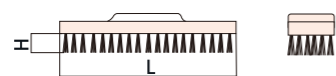

货号		规格			重量(g)	
黄铜	磷铜	L*B(mm)	Rows	H(mm)	黄铜	磷铜
BR286D-1002	PH286D-1002	210-65	6*17	40	500	500

防爆试管刷
Brush, Tube



货号		规格			重量(g)	
黄铜	磷铜	Φ(mm)	L1(mm)	L(mm)	黄铜	磷铜
BR287-1002	PH287-1002	20	100	320	100	100

防爆杆平刷
Brush, Wheel



货号		规格			重量(g)	
黄铜	磷铜	Φ(mm)	H(mm)	Φ2(mm)	黄铜	磷铜
BR288-1002	PH288-1002	75	10	6	140	140

防爆扭丝轮刷
Wheel Brush, Knot Wire

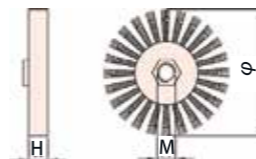

货号		规格			重量(g)	
黄铜	磷铜	Φ(mm)	H(mm)	Φ2(mm)	黄铜	磷铜
BR289-1002	PH289-1002	125	15	14	440	440

防爆轮刷
Brush, Wheel, Crimped Wire

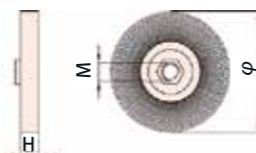

货号		规格			重量(g)	
黄铜	磷铜	Φ(mm)	H(mm)	M(mm)	黄铜	磷铜
BR289A-1002	PH289A-1002	125	15	14	320	320

防爆杯刷
Brush, Cup

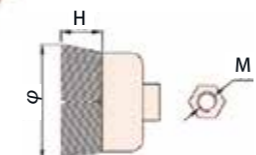

货号		规格			重量(g)	
黄铜	磷铜	Φ(mm)	H(mm)	M(mm)	黄铜	磷铜
BR290-1002	PH290-1002	100	30	14	480	480

防爆扭丝杯刷
Cup Brush, Knot Wire

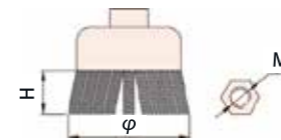

货号		规格			重量(g)	
黄铜	磷铜	Φ(mm)	H(mm)	M(mm)	黄铜	磷铜
BR290A-1002	PH290A-1002	100	30	14	580	580

防爆笔刷
Brush, End

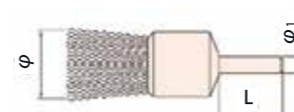

货号		规格			重量(g)	
黄铜	磷铜	Φ(mm)	H(mm)	Φ2(mm)	黄铜	磷铜
BR290B-1002	PH290B-1002	26	25	6	120	120

防爆清洁刷
Brush, Ball

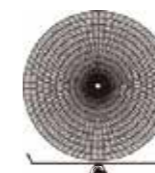

货号		重量(g)	
黄铜	磷铜	黄铜	磷铜
BR286-1002		25	

防爆锄头
Hoe

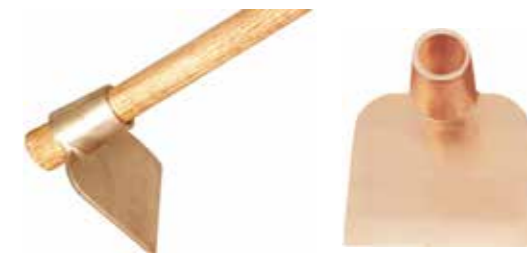

货号		规格		重量(g)	
铝青铜合金	铍青铜合金	B(mm)	H(mm)	铝青铜合金	铍青铜合金
AL291-1002	BE291-1002	130	130	970	1080
AL291-1004	BE291-1004	200	200	1600	1780

防爆索具卸扣
Shackle

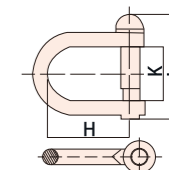

货号		规格			重量(g)	
铝青铜合金	铍青铜合金	Size(T)	K(mm)	H(mm)	铝青铜合金	铍青铜合金
AL292-1002	BE292-1002	1	30	40	130	130
AL292-1004	BE292-1004	2	33	45	500	500
AL292-1006	BE292-1006	3	37	78	8300	830
AL292-1008	BE292-1008	5	45	110	1700	1700
AL292-1010	BE292-1010	10	60	120	4000	4000

防爆手摇油泵
Manual Portable Oil Pump



货号		规格		重量(g)	
铝青铜合金	铍青铜合金	L(mm)	D(mm)	铝青铜合金	铍青铜合金
AL293-1002	BE293-1002	1350	25	5700	6000

防爆可调提桶钩
Barrel Hook, Adjustable

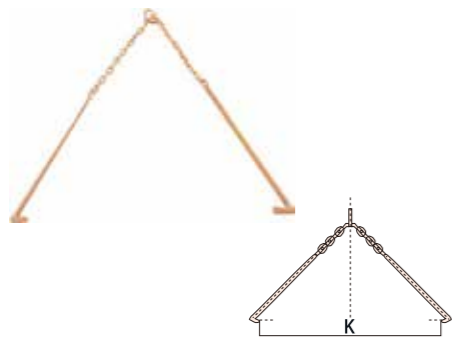

货号		规格		重量(g)	
铝青铜合金	铍青铜合金	H(mm)	K(mm)	铝青铜合金	铍青铜合金
AL294-1002	BE294-1002	700	1060	3050	3300

防爆卡兰
Screw Clamp

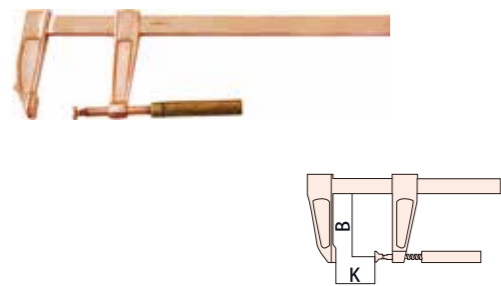

货号		规格		重量(g)	
铝青铜合金	铍青铜合金	B(mm)	Kmax(mm)	铝青铜合金	铍青铜合金
AL295-1002	BE295-1002	120	400	2200	2395

防爆耙子
Rake

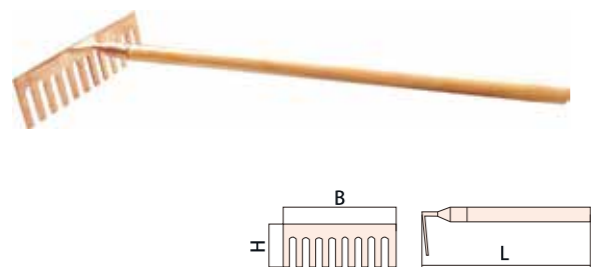

货号		规格			重量(g)	
铝青铜合金	铍青铜合金	L(mm)	B(mm)	H(mm)	铝青铜合金	铍青铜合金
AL296-1002	BE296-1002	1270	350	100	1935	2080
AL296-1004	BE296-1004	1275	450	120	2135	2300

防爆凿子
Chisel

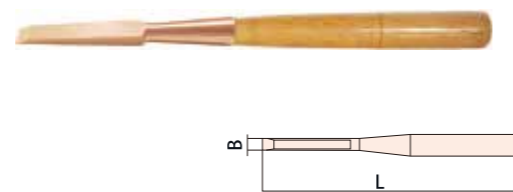

货号		规格		重量(g)	
铝青铜合金	铍青铜合金	B(mm)	L(mm)	铝青铜合金	铍青铜合金
AL297-1002	BE297-1002	14	280	180	200
AL297-1004	BE297-1004	18	320	250	270

防爆耙子
Rake

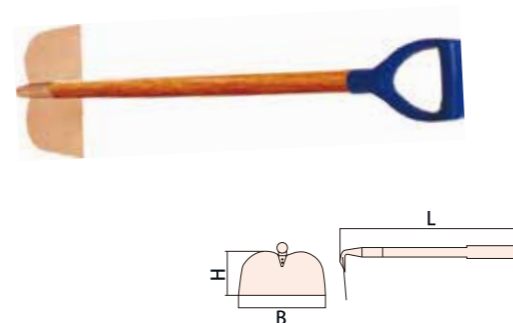

货号		规格			重量(g)	
铝青铜合金	铍青铜合金	B(mm)	H(mm)	L(mm)	铝青铜合金	铍青铜合金
AL298-1002	BE298-1002	300	150	1130	1400	1550

防爆耙子
Rake

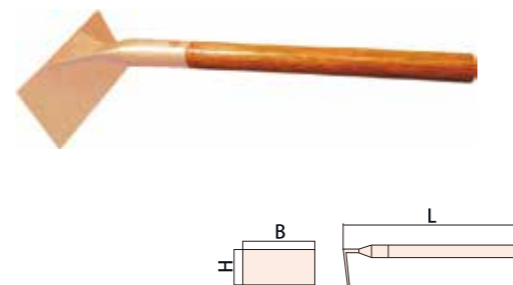

货号		规格			重量(g)	
铝青铜合金	铍青铜合金	B(mm)	H(mm)	L(mm)	铝青铜合金	铍青铜合金
AL299-1002	BE299-1002	160	80	780	600	670

防爆消防钩
Fire, Hook

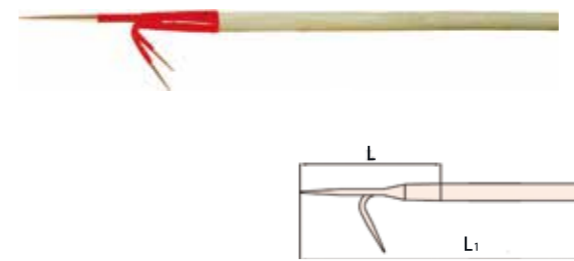

货号		规格		重量(g)	
铝青铜合金	铍青铜合金	L(mm)	L1(mm)	铝青铜合金	铍青铜合金
AL300-1002	BE300-1002	270	1215	1300	1365

防爆管子台虎钳
Self Locking Pipe Vice

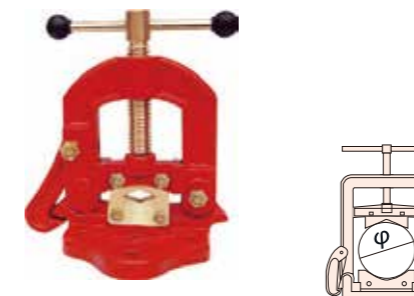

货号		规格		重量(g)	
铝青铜合金	铍青铜合金	D(mm)		铝青铜合金	铍青铜合金
AL301-1002	BE301-1002	10-60		4425	4870
AL301-1004	BE301-1004	10-90		9420	10350
AL301-1006	BE301-1006	15-115		13900	15300
AL301-1008	BE301-1008	30-220		27800	30600
AL301-1010	BE301-1010	30-300		35000	38000

防爆链条调节器
Chain Adjuster



货号		规格			重量(g)	
铝青铜合金	铍青铜合金	S(mm)	Load(T)	L(mm)	铝青铜合金	铍青铜合金
AL302-1002	BE302-1002	6	1.12	73	200	225
AL302-1004	BE302-1004	8	2	100	450	500
AL302-1006	BE302-1006	10	3.15	137	1150	1280

防爆安全带
Safety Belt



货号		规格		重量(g)	
铝青铜合金	铍青铜合金	Size		铝青铜合金	铍青铜合金
AL303-1002		全身型			1200
AL303-1004		双肩型			1000

防爆弯管器
Tube Bender



货号		规格		重量(g)	
铝青铜合金	铍青铜合金	Size(mm)		铝青铜合金	铍青铜合金
AL304-1002	BE304-1002	6、8、10		1420	460
AL304-1004	BE304-1004	12		1500	1650
AL304-1006	BE304-1006	14		1800	2000

防爆管子割刀
Pipe Cutter

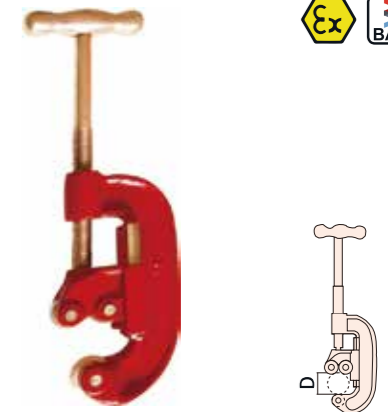

货号		规格		重量(g)	
铝青铜合金	铍青铜合金	D(inch)	D(mm)	铝青铜合金	铍青铜合金
AL305-1002	BE305-1002	3/8-2	10-50	2010	2210
AL305-1004	BE305-1004	3/8-3	10-75	3700	4070

防爆棘轮插头
Rectangular Reversible Ratchet Head

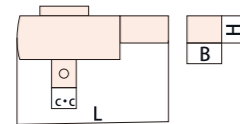
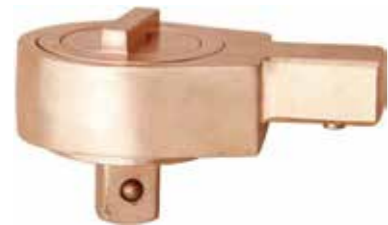

货号		规格			重量(g)	
铝青铜合金	铍青铜合金	H*(mm)	C(inch)	L(mm)	铝青铜合金	铍青铜合金
AL309B-1002	BE309B-1002	9*12	3/8	50	150	165
AL309B-1004	BE309B-1004	14*18	1/2	78	400	445

防爆法兰支开器
Flange Prop



货号		规格		重量(g)	
铝青铜合金	铍青铜合金	Size(mm)		铝青铜合金	铍青铜合金
AL310-1002	BE310-1002	FZM16-24		6600	7300
AL310-1004	BE310-1004	FZM27-36		9000	9900

防爆台虎钳
Parallel Vice

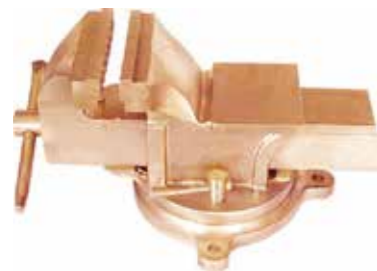

货号		规格		重量(g)	
铝青铜合金	铍青铜合金	B(mm)	Kmax(mm)	铝青铜合金	铍青铜合金
AL311-1002	BE311-1002	90	90	7400	8150
AL311-1004	BE311-1004	125	125	16800	19550
AL311-1006	BE311-1006	150	150	26500	30000
AL311-1008	BE311-1008	170	170	27400	30300

防爆手虎钳
Hand Vise

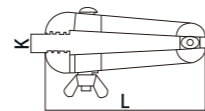

货号		规格		重量(g)	
铝青铜合金	铍青铜合金	K(mm)	L(mm)	铝青铜合金	铍青铜合金
AL311A-50	BE311A-50	50	165	830	915

防爆钻头
Drill Bit



货号		规格		重量(g)	
铍青铜合金		Φ(mm)	L(mm)	铍青铜合金	
BE312-1002		6	100	20	
BE312-1004		7	120	30	
BE312-1006		8	140	50	
BE312-1008		9	160	75	
BE312-1010		10	180	100	
BE312-1012		11	200	120	
BE312-1014		12	220	170	
BE312-1016		13	240	220	
BE312-1018		14	260	280	
BE312-1020		15	280	360	
BE312-1022		16	300	440	
BE312-1024		17	300	500	
BE312-1026		18	320	600	
BE312-1028		19	320	700	
BE312-1030		20	330	800	

防爆人体静电释放仪
Releasing Static Device



货号		规格		重量(g)	
铝青铜合金	铍青铜合金	L(mm)	D(mm)	铝青铜合金	铍青铜合金
AL313-1002	BE313-1002	1150	90	3700	3900

电子型防爆人体静电释放仪
Releasing Static Device



货号		规格		重量(g)	
铝青铜合金	铍青铜合金	L(mm)	D(mm)	铝青铜合金	铍青铜合金
AL313A-1002	BE313A-1002	1150	90	4200	4300

防爆人体静电释放仪
Releasing Static Device



货号		规格		重量(g)	
铝青铜合金	铍青铜合金	L(mm)	D(mm)	铝青铜合金	铍青铜合金
AL313B-1002	BE313B-1002	1000	90	2700	2900

防爆千斤顶
Screw Jack



货号		规格			
铝青铜合金	铍青铜合金	Model(kg)	Capacity(mm)	MIN.H(mm)	Lifting(mm)
AL314-1002	BE314-1002	FBQL3.2	3.2	220	110
AL314-1004	BE314-1004	FBQL35	5	250	130
AL314-1006	BE314-1006	FBQL10	10	280	150
AL314-1008	BE314-1008	FBQL16	16	320	180

防爆盘根工具
Packing Tool



货号		重量(g)	
铝青铜合金	铍青铜合金	铝青铜合金	铍青铜合金
AL315-1002	BE315-1002	800	900

防爆液压千斤顶
Hydraulic Screw Jack



● 液缸 Hydraulic Cylinder

货号		规格			重量(g)	
铝青铜合金	铍青铜合金	Model(inch)	Height(mm)	Lifting(mm)	铝/铍青铜合金	
AL316-1002	BE316-1002	ZBYG-10B	48	58	1600	
AL316-1004	BE316-1004	ZBYG-20B	56	67	2700	
AL316-1006	BE316-1006	ZBYG-30B	62	75	4600	
AL316-1008	BE316-1008	ZBYG-50B	72	88	7800	

● 泵浦 Pumps

货号		规格			重量(g)	
铝青铜合金	铍青铜合金	Model	Working Pressure	Oil capacity (L)	铝/铍青铜合金	
AL316A-1002	BE316A-1002	ZBB-700C	70	600-350	110	

防爆尺子
Ruler



货号		规格		重量(g)	
铝青铜合金	铍青铜合金	Size(mm)		铝青铜合金	铍青铜合金
AL317-1002	BE317-1002	500		190	140
AL317-1004	BE317-1004	1000		390	290

防爆工具系列
NON-SPARKING TOOLS

防爆工具系列
NON-SPARKING TOOLS

防爆丁字尺

T Square



货号	规格	重量(g)
黄铜	Size(mm)	黄铜
BR318-1002	1000	1450

防爆塞尺

Filler Gauge



货号	规格	重量(g)
黄铜	Size(mm)	黄铜
BR319-1002	0.05-1.0	70

防爆直角尺

Filler Gauge



货号	规格	重量(g)
铝青铜合金	Size(mm)	铝青铜合金
AL320-1002	150*300	145
AL320-1004	250*500	275

防爆封盖器

Block Device



货号	规格	重量(g)
铝青铜合金	L(mm) Φ(mm)	铝青铜合金
AL323-1002	390 35	1150
AL323-1004	390 75	2650

防爆套装双头呆扳手

Double Open End Wrench Set



货号	规格	重量(g)
铝青铜合金	规格 SPECIFICATION(mm)	铝铜 铍铜
ALA-9	BEA-9 8*10,10*12,12*14,14*17,17*19,19*22,22*24,24*27,30*32	2570 2810
ALA-10	BEA-10 8*10,10*12,12*14,14*17,17*19,19*22,22*24,24*27,27*30,30*32	3000 3295
ALA-11	BEA-11 8*10,9*11,10*12,12*14,14*17,17*19,19*22,22*24,24*27,27*30,30*32	3230 3530
ALA-12	BEA-12 6*7,8*9,10*11,12*13,14*15,16*17,18*19,20*22,21*23,24*26,25*28,30*32	2612 2869
ALA-13	BEA-13 5.5*7,6*7,8*10,9*11,10*12,12*14,14*17,17*19,19*22,22*24,24*27,27*30,30*32	3295 3610

防爆套装呆梅扳手

Combination Wrench Set



货号	规格	重量(g)
铝青铜合金	规格 SPECIFICATION(mm)	铝铜 铍铜
ALB-9	BEB-9 8,10,12,14,17,19,22,24,27	1655 1815
ALB-10	BEB-10 10,12,14,17,19,22,24,27,30,32	2721 3008
ALB-11	BEB-11 8,10,12,14,17,19,22,24,27,30,32	2955 3235
ALB-12	BEB-12 6,8,10,12,14,17,19,22,24,27,30,32	2975 3257
ALB-13	BEB-13 8,10,12,13,14,16,17,19,22,24,27,30,32	3175 3485

防爆套装双头梅花扳手

Double Box Offset Wrench Set



货号	规格	重量(g)
铝青铜合金	规格 SPECIFICATION(mm)	铝铜 铍铜
ALC-9	BEC-9 8*10,10*12,12*14,14*17,17*19,19*22,22*24,24*27,30*32	2575 2815
ALC-10	BEC-10 8*10,10*12,12*14,14*17,17*19,19*22,22*24,24*27,27*30,30*32	3460 3520
ALC-11	BEC-11 8*10,9*11,10*12,12*14,14*17,17*19,19*22,22*24,24*27,27*30,30*32	3275 3585
ALC-12	BEC-12 6*7,8*9,10*11,12*13,14*15,16*17,18*19,20*22,21*23,24*26,25*28,30*32	3631 3965
ALC-13	BEC-13 5.5*7,6*7,8*10,9*11,10*12,12*14,14*17,17*19,19*22,22*24,24*27,27*30,30*32	3320 3630

防爆6件套组合套装工具

Tool Set-6pcs



货号	名称	规格
AL01-6	BE01-6	
铝青铜合金	铍青铜合金	DESCRIPTION SPECIFICATION
	一字螺丝刀	Slotted Screwdriver 5*75mm
	十字螺丝刀	Phillips Screwdriver #2*125mm
	活扳手	Wrench, Adjustable 200mm
	羊角锤	Hammer, Claw 230mm
	新式水夹钳	Pliers, Water Pump 10"
	新式水夹钳	Pliers, Adjustable Combination 6"
	美式管钳子	Wrench, Pipe (American Type)
	箱子	Tool Case

防爆9件套组合套装工具

Tool Set-9pcs



货号	名称	规格
AL02-9	BE02-9	
铝青铜合金	铍青铜合金	DESCRIPTION SPECIFICATION
	活扳手	Wrench, Adjustable 300mm
	宽丝钳	Pliers, Lineman 200mm
	水夹钳	Pliers, Water Pump 250mm
	一字螺丝刀	Slotted Screwdriver 6*150mm
	十字螺丝刀	Phillips Screwdriver 8*200mm
	装柄机械锤	Hammer, Cross Pein Engineers' 1kg
	泥子刀	Knife, Putty 50*203mm
	箱子	Tool Case

防爆10件套组合套装工具

Tool Set-10pcs



货号	名称	规格
AL03-10	BE03-10	
铝青铜合金	铍青铜合金	DESCRIPTION SPECIFICATION
	一字螺丝刀	Slotted Screwdriver 5/16*3"
	十字螺丝刀	Phillips Screwdriver #2*4"
	活扳手	Wrench, Adjustable 6", 10"
	羊角锤	Hammer, Claw 0.45kg
	新式水夹钳	Pliers, Water Pump 10"
	木柄腻子刀	Knife, Putty 1-1/4*3-9/16"
	木柄腻子刀	Knife, Common 3-1/8"
	鲤鱼钳	Pliers, Adjustable Combination 6"
	美式管钳子	Wrench, Pipe (American Type) 10"
	箱子	Tool Case

防爆钻头15件套

Drill Bits Set-15pcs

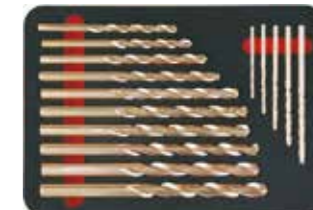

货号	名称	规格
AL04-15	BE04-15	
铝青铜合金	铍青铜合金	DESCRIPTION SPECIFICATION
	钻头	Drill Bit 6*100mm, 7*120mm, 8*140mm, 9*160mm, 10*180mm, 11*200mm, 12*220mm, 13*240mm, 14*260mm, 15*280mm, 16*300mm, 17*300mm, 18*320mm, 19*320mm, 20*330mm

防爆15件套组合套装工具
Tool Set-15pcs



货号	名称	规格
铝青铜合金	铍青铜合金	SPECIFICATION
AL05-15	BE05-15	
	活扳手Wrench, Adjustable	300mm
	克丝钳Pliers, Lineman	200mm
	水泵钳Pliers, Water Pump	250mm
	一字螺丝刀	6*150mm
	Slotted Screwdriver	8*200mm
	十字螺丝刀	#2*150mm
	Phillips Screwdriver	#3*200mm
	装柄机械锤Hammer, Cross Pein Engineers'	1kg
	泥子刀Knife, Putty	50*203mm
	箱子Tool Case	

防爆16件套组合套装工具
Tool Set-16pcs



货号	名称	规格
铝青铜合金	铍青铜合金	SPECIFICATION
AL07-16	BE07-16	
	一字螺丝刀	3*75mm
	十字螺丝刀	Phillips Screwdriver #3*200mm
	活扳手	Wrench, Adjustable 8" 12"
	羊角锤	Hammer, Claw 0.45kg
	起钉锤	Crate Opener 230mm
	新式水泵钳	Pliers, Water Pump 12"
	木柄泥子刀	Knife, Putty 200MM
	塑料刮皮刀	Knife 250MM
	铁皮剪刀	Shears, Tin 12"
	尖嘴钳	Pliers, Long Nose 8"
	鲤鱼钳	Pliers, Adjustable Combination 8"
	除锈铲	Scraper, Spray Booth 3"
	刮刀	Scraper, Deck 380mm
	美式管钳	Wrench, Pipe (American Type) 14"
	开桶扳手	Wrench, Bung 300mm
	箱子	Tool Case

防爆16件套组合套装工具
Tool Set-16pcs



货号	名称	规格
铝青铜合金	铍青铜合金	SPECIFICATION
AL09-16	BE09-16	
	防爆十字螺丝刀	Phillips Screwdriver #1*75mm #1*100mm
	防爆一字螺丝刀	Slotted Screwdriver 4*100mm, 5*100mm
	防爆球头内六角	Wrench, Hex Key with Ball (2,3,4,5,6,8,10) mm
	防爆克丝钳	Pliers, Lineman 6"
	斜口钳	Pliers, Diagonal Cutting 6"
	防爆尖嘴钳	Pliers, Long Nose 6"
	新式水泵钳	Pliers, Water Pump 250mm
	防爆活扳手	Wrench, Adjustable 24*200mm
	箱子	Case

防爆17件套组合套装工具
Tool Set-17pcs



货号	名称	规格
铝青铜合金	铍青铜合金	SPECIFICATION
AL11-17	BE11-17	
	圆嘴钳	Pliers, Round Nose 150mm
	鸭嘴钳	Pliers, Flat Nose 150mm
	斜嘴钳	Pliers, Diagonal Cutting 150mm
	克丝钳	Pliers, Lineman 150mm
	镊子	Tweezer, Neat Tips 150mm
	剥线钳	Wire Stripping Pliers 170mm
	活扳手	Wrench, Adjustable 18*150mm
	一字螺丝刀	Slotted Screwdriver 3*75mm, 4*100mm
	十字螺丝刀	Phillips Screwdriver #0*50mm #1*75mm
	球头内六角扳手	Wrench, Hex Key with Ball 3mm, 4mm, 5mm
	削皮刀	Knife 250mm
	裁剪刀	Scissors 225mm
	箱子	Tool Case

防爆16件套组合套装工具
Tool Set-16pcs



货号	名称	规格
铝青铜合金	铍青铜合金	SPECIFICATION
AL06-16	BE06-16	
	双头梅花扳手	8*10mm 10*12mm
	Wrench, Double Flat Box(DIN837)	14*17mm 19*22mm
	活扳手 Wrench, Adjustable	250mm
	管钳子 Wrench, Pipe (American Type)	350mm
	新式水泵钳 Pliers, Water Pump	250mm
	鲤鱼钳Pliers, Adjustable Combination	150mm 200mm
	一字螺丝刀 Slotted Screwdriver	6*150mm
	十字螺丝刀 Phillips Screwdriver	#2*150mm
	装柄羊角锤 Hammer, Claw	0.45kg
	泥子刀 Knife, Putty	25*200mm
	削皮刀 Knife	250mm
	两头扁刮刀 Scraper, Deck	45*300mm
	木柄刷 Brush	4*16mm
	箱子 Tool Case	

防爆15件套组合套装工具
Tool Set-15pcs



货号	名称	规格
铝青铜合金	铍青铜合金	SPECIFICATION
AL08-15	BE08-15	
	泥子刀	Knife, Putty 50*203mm
	新式水泵钳	Pliers, Water Pump 300mm
	铁皮剪刀	Shears, Tin 300mm
	活扳手	Wrench, Adjustable 24*200mm, 36*300mm
	多用开桶扳手	Wrench, Bung 385mm
	克丝钳	Pliers, Lineman 200mm
	尖嘴钳	Pliers, Long Nose 200mm
	羊角锤	Hammer, Claw 680g
	弯柄刷	Brush, Shoe handle 4*16mm
	削皮刀	Knife 137*250mm
	刮刀	Scraper, Deck 300mm
	一字螺丝刀	Slotted Screwdriver 6*150mm
	十字螺丝刀	Phillips Screwdriver 8*200mm
	美式管钳子	Wrench, Pipe (American Type) 50*350mm
	箱子	Tool Case

防爆17件套组合套装工具
Tool Set-17pcs



货号	名称	规格
铝青铜合金	铍青铜合金	SPECIFICATION
AL10-17	BE10-17	
	管钳子	Wrench, Pipe (American Type) 350mm
	活扳手	Wrench, Adjustable 200mm, 300mm
	呆梅两用扳手	Wrench, Combination (14,17,19,22,24,27)mm
	克丝钳	Pliers, Lineman 200mm
	尖嘴钳	Pliers, Long Nose 200mm
	鲤鱼钳	Pliers, Adjustable Combination 200mm
	钎子	Punch, Machinists' Φ18*160mm
	扁铲	Chisel, Flat Φ18*160mm
	一字螺丝刀	Slotted Screwdriver 6*150mm
	十字螺丝刀	Phillips Screwdriver #2*150mm
	装柄奶头锤	Hammer, Ball Pein 0.91kg
	箱子	Tool Case

防爆17件套组合套装工具
Tool Set-17pcs



货号	名称	规格
铝青铜合金	铍青铜合金	SPECIFICATION
AL12-17	BE12-17	
	羊角起钉钳	Bar, Wrecking 19*800mm
	活扳手	Wrench, Adjustable 30*250mm
	奶头锤	Hammer, Ball Pein 450g 680g
	除锈锤	Hammer, Scaling 300g
	八角锤	Hammer, Sledge 2500g
	刮刀	Scraper, Deck 300mm
	弧形除锈铲	Scraper, Arched 100mm
	一字螺丝刀	Slotted Screwdriver 8*200mm
	六角扁铲	Chisel Hex/6 Point 18*160mm
	圆形扁铲	Chisel, Flat 24*250mm
	美式管钳子	Wrench, Pipe (American Type) 200mm
	箱子	Tool Case 250mm, 50*350mm

防爆工具系列
NON-SPARKING TOOLS

防爆工具系列
NON-SPARKING TOOLS

防爆20件套组合套装工具

Tool Set-20pcs



货号	名称	规格
铝青铜合金	DESCRIPTION	SPECIFICATION
AL13-20	十字螺丝刀	#1*75mm
	一字螺丝刀	5*100mm
	克丝钳	6"
	活扳手	12"
	管钳子	250mm
	装柄八角锤	4p
	泥子刀	65*203mm
	呆梅两用扳手	(8,10,12,13,14,17,19,22,24) mm
	圆形扁铲	14*160mm
	钎子	20*300mm
	内六角	4mm
	斜口钳	6"
	箱子	

防爆26件套组合套装工具

Tool Set-26pcs



货号	名称	规格
铝青铜合金	DESCRIPTION	SPECIFICATION
AL15-26	圆扁铲	18*200mm
	活扳手	150mm
	克丝钳	200mm
	鲤鱼钳	200mm
	尖嘴钳	150mm
	一字螺丝刀	6*150mm 8*200mm
	十字螺丝刀	#2*150mm #3*200mm
	1/2"套筒头	(8,10,12,14,17)mm
	滑杆手柄	1/2"*250mm
	装柄检验锤	0.15kg
	呆梅两用扳手	(8,10,12,14,17)mm
	内六角扳手	(4,5,6,8,10)mm
	箱子	

防爆28件套组合套装工具

Tool Set-28pcs



货号	名称	规格
铝青铜合金	DESCRIPTION	SPECIFICATION
AL17-28	装柄八角锤	1.8kg
	装柄奶头锤	0.91kg
	装柄羊角锤	0.45kg
	管钳子	300mm, 450mm
	活扳手	200mm, 300mm
	呆梅两用扳手	(8,10,12,14,17,19,22,24,27,30,32) mm
	克丝钳	200mm
	尖嘴钳	200mm
	鲤鱼钳	200mm
	撬棍	Φ25*500mm
	扁铲	Φ25*300mm
	一字螺丝刀	6*100mm 8*200mm
	十字螺丝刀	#1*100mm #3*200mm
	F扳手	400mm
箱子		

防爆28件套组合套装工具

Tool Set-28pcs



货号	名称	规格
铝青铜合金	DESCRIPTION	SPECIFICATION
AL18-28	十字螺丝刀	#1*100mm #2*150mm
	一字螺丝刀	5*100mm 7*150mm
	呆梅两用扳手	(8,10,12,14,17,19,22,24,27,30,32,36) mm
	活扳手	24*200mm
	管钳子	30*250mm, 36*300mm
	克丝钳	60*450mm
	箱子	50*350mm, 75*600mm 8"

防爆36件套组合套装工具

Tool Set-36pcs



货号	名称	规格
铝青铜合金	DESCRIPTION	SPECIFICATION
AL20-36	凹槽双头呆扳手	(5.5*7, 6*7, 8*10, 9*11, 10*12, 12*14, 14*17, 17*19, 19*22, 22*24, 24*27, 27*30, 30*32) mm
	防爆呆梅两用扳手	(8, 10, 13, 16, 30, 32) mm
	管钳子	300mm
	活扳手	450mm
	装柄奶头锤	450g
	箱子	

防爆20件套组合套装工具

Tool Set-20pcs



货号	名称	规格
铝青铜合金	DESCRIPTION	SPECIFICATION
AL14-20	美式管钳子	50*350
	呆梅两用扳手	(10,11,12,13,14,17,19,22)mm
	十字螺丝刀	#1*100mm
	一字螺丝刀	150*8mm
	活扳手	30*250mm
	克丝钳	200mm
	尖嘴钳	200mm
	羊角锤	680g
	弯柄刷	4*16
	刮刀	300mm
	泥子刀	25*200
	削皮刀	137*250
	新式水泵钳	250mm
	箱子	

防爆26件套组合套装工具

Tool Set-26pcs



货号	名称	规格
铝青铜合金	DESCRIPTION	SPECIFICATION
AL16-26	管钳子	450mm, 250mm
	活扳手	375mm, 300mm
	装柄奶头锤	200mm, 150mm
	克丝钳	0.91kg
	尖嘴钳	200mm
	一字螺丝刀	6*150mm, 8*200mm
	十字螺丝刀	#2*150mm #3*200mm
	F扳手	500mm
	双头梅花扳手	30*27mm, 27*24mm
	双头呆扳手	24*22mm, 22*19mm
	双头呆扳手	19*17mm, 17*14mm
	双头呆扳手	30*32mm, 27*30mm
	双头呆扳手	24*27mm, 22*24mm
	箱子	19*22mm, 17*19mm

防爆34件套组合套装工具

Tool Set-34pcs



货号	名称	规格
铝青铜合金	DESCRIPTION	SPECIFICATION
AL19-34	双头呆扳手	(6*7, 8*10, 9*11, 10*12, 12*13, 14*15, 16*18, 17*19, 20*22, 21*23, 24*27, 27*30, 32*36)mm
	内六角	1/16", 3/32"
	一字螺丝刀	(2, 3, 4, 5, 6, 8, 10)mm
	十字螺丝刀	8*150mm, 5*100mm
	镊子	3*50mm, 5*100mm, 6*150mm
	新式水泵钳	150mm
	活扳手	250mm
	斜嘴钳	250mm
	尖嘴钳	6"
	箱子	6"

防爆36件套组合套装工具

Tool Set-36pcs



货号	名称	规格
铝青铜合金	DESCRIPTION	SPECIFICATION
AL21-36	镊子	200mm
	T型钎子	187mm
	削皮刀	193mm
	剪刀	225mm
	锯弓子	500mm
	锯条	300mm
	泥子刀	40*200mm
	长柄圆头刷	350*28mm
	一字螺丝刀	3*50mm
	S型螺丝刀	4*75mm, 6*100mm
	十字螺丝刀	8*150mm, 8*200mm
	鲤鱼钳	6*72mm
	尖嘴钳	8*125mm, 10*196mm
	斜嘴钳	#1*75mm, #2*125mm
	圆嘴钳	#3*200mm, #4*300mm
	克丝钳	200mm
	活扳手	150mm, 250mm
	美式管钳子	350mm
	奶头锤	0.68kg
	英式平顶锤	4LB
圆形扁铲	16*160mm	
撬棍	25*300mm	
羊角起钉钳	15*500mm	
箱子	400mm	

防爆36件套组合套装工具

Tool Set-36pcs



货号	名称	规格
铝青铜合金	DESCRIPTION	SPECIFICATION
AL22-36	装柄八角锤	Hammer, Sledge
	装柄奶头锤	Hammer, Ball Pein
BE22-36	美式管钳	Wrench, Pipe (American Type)
	活扳手	Wrench, Adjustable
	呆梅两用扳手	Wrench, Combination
	克丝钳	Pliers, Lineman
	尖嘴钳	Pliers, Long Nose
	鲤鱼钳	Pliers, Round Nose
	可调组合钳	Pliers, Adjustable Combination
	圆嘴钳	Pliers, Round Nose
	鸭嘴钳	Pliers, Flat Nose
	斜口钳	Pliers, Diagonal Cutting
	一字螺丝刀	Slotted Screwdriver
	十字螺丝刀	Phillips Screwdriver
	S型螺丝刀	Slotted Offset Screwdriver
	八角扁铲	Chisel 8 Point
	剪刀	Shears, Cutting
	削皮刀	Knife
	泥子刀	Knife, Putty
	镊子	Tweezer, Neat Tips
	撬棍	Bar
	T型杆	Marking Tool
	羊角起钉钳	Bar, Wrecking
	锯弓子	Hacksaw Frame
	锯条	Hacksaw Blade
	刷子	Brush, Flat Back, Scratch
	箱子	Tool Case

防爆40件套组合套装工具

Tool Set-40pcs



货号	名称	规格
铝青铜合金	DESCRIPTION	SPECIFICATION
AL24-40	装柄八角锤	Hammer, Sledge
	装柄羊角锤	Hammer, Claw
BE24-40	装柄奶头锤	Hammer, Ball Pein
	防爆管钳子	Wrench, Pipe (American Type)
	活扳手	Wrench, Adjustable
	克丝钳	Pliers, Lineman
	尖嘴钳	Pliers, Long Nose
	鸭嘴钳	Pliers, Flat Nose
	斜口钳	Pliers, Diagonal Cutting
	鲤鱼钳	Pliers, Round Nose
	可调组合钳	Pliers, Adjustable Combination
	胡桃钳	Pincers
	剪刀	Shears, Cutting
	一字螺丝刀	Slotted Screwdriver
	十字螺丝刀	Phillips Screwdriver
	S型螺丝刀	Slotted Offset Screwdriver
	六角扁铲	Chisel Hex/6 Point
	起钉器	Bar, Wrecking
	削皮刀	Knife
	泥子刀	Knife, Putty
	镊子	Tweezer, Neat Tips
	三角锥	File, Triangle
	听针	Hearing Needle
	T型杆	Marking Tool
	鸡尾锯	Hand saw
	锯弓子	Hacksaw Frame
	锯条	Hacksaw Blade
	刷子	Brush, Flat Back, Scratch
	箱子	Tool Case

防爆50件套组合套装工具

Tool Set-50pcs



货号	名称	规格
铝青铜合金	DESCRIPTION	SPECIFICATION
AL25-50	装柄八角锤	Hammer, Sledge
	装柄奶头锤	Hammer, Ball Pein
BE25-50	装柄羊角锤	Hammer, Claw
	防爆管钳子	Wrench, Pipe (American Type)
	活扳手	Wrench, Adjustable
	防爆呆梅两用扳手	Wrench, Combination
	克丝钳	Pliers, Lineman
	尖嘴钳	Pliers, Long Nose
	鲤鱼钳	Pliers, Round Nose
	可调组合钳	Pliers, Adjustable Combination
	撬棍	Bar
	扁铲	Chisel, Flat
	杆子	Punch, Machinists'
	一字螺丝刀	Slotted Screwdriver
	十字螺丝刀	Phillips Screwdriver
	F型扳手	Valve Handle
	削皮刀	Knife
	锯弓子	Hacksaw Frame
	锯条	Hacksaw Blade
	1/2"套筒头	Socket (1/2")
	棘轮扳手	Ratchet Wrench
	接杆1/2"	Driver Extension
	快速手柄	Speed Handle
	滑杆手柄	Sliding T Handle
	万向接头	Universal Joint
	泥子刀	Knife, Putty
	箱子	Tool Case

防爆62件套组合套装工具

Tool Set-62pcs



货号	名称	规格
铝青铜合金	DESCRIPTION	SPECIFICATION
AL26-62	活扳手	Wrench, Adjustable
	呆梅两用扳手	Wrench, Combination
BE26-62	英制呆梅扳手	Wrench, Combination
	美式管钳子	Wrench, Pipe (American Type)
	叠置式水泵钳	Pliers, Groove Joint
	鲤鱼钳	Pliers, Round Nose
	可调组合钳	Pliers, Adjustable Combination
	克丝钳	Pliers, Lineman
	尖嘴钳	Pliers, Long Nose
	一字螺丝刀	Slotted Screwdriver
	十字螺丝刀	Phillips Screwdriver
	羊角起钉钳	Bar, Wrecking
	尖嘴钳	Bar, Pinch
	削皮刀	Knife
	泥子刀	Knife, Putty
	两头扁刮刀	Scraper, Deck
	多用开桶扳手	Wrench, Bung
	圆型扁铲	Chisel, Flat
	装柄机械锤	Hammer, Cross Pein Engineers'
	装柄羊角锤	Hammer, Claw
	1/2"套筒头	Socket (1/2")
	棘轮扳手	Ratchet Wrench
	1/2"转向手柄	Hinged Handle
	箱子	Tool Case

防爆37件套组合套装工具

Tool Set-37pcs



货号	名称	规格
铝青铜合金	DESCRIPTION	SPECIFICATION
AL23-37	呆梅两用扳手	Wrench, Combination
	新式水泵钳	Pliers, Water Pump
BE23-37	削皮刀	Knife
	泥子刀	Knife, Putty
	弯柄刷	Brush, Shoe handle
	内六角扳手	Wrench, Hex Key
	克丝钳	Pliers, Lineman
	斜口钳	Pliers, Diagonal Cutting
	45°瑞典水泵钳	Wrench, Swedish Type 45°
	活扳手	Wrench, Adjustable
	机械锤	Hammer, Cross Pein Engineers'
	德式八角锤	Hammer, Sledge (German Type)
	一字螺丝刀	Slotted Screwdriver
	十字螺丝刀	Phillips Screwdriver
	圆形扁铲	Chisel, Flat
	平尖铲	Chisel, Cross Cutting
	平头冲子	Punch
	裁剪刀	Scissors
	箱子	Tool Case

NON-SPARKING TOOLS
防爆工具系列

NON-SPARKING TOOLS
防爆工具系列

防爆68件套组合套装工具

Tool Set-68pcs



防爆85件套组合套装工具

Tool Set-85pcs



NON-SPARKING TOOLS
防爆工具系列

货号	名称	规格	
铝青铜合金	DESCRIPTION	SPECIFICATION	
AL27-68	1/2"套筒头 Socket (1/2")	8mm	
		10mm	
		12mm	
		13mm	
		15mm	
		17mm	
		18mm	
		19mm	
		22mm	
		24mm	
		27mm	
		30mm	
		内六角套筒头 Internal Hexagon Socket	1/4"8
			1/4"10
			1/2"12mm
	万向接头 Universal Joint	1/2"80	
		换向棘轮扳手 Ratchet Wrench	1/2"245
		套筒连接杆 Driver Extension	1/2"100
	活扳手 Wrench, Adjustable	18"150	
		24"200	
	呆梅两用扳手 Wrench, Combination	36"300	
		7mm	
		8mm	
		10mm	
		12mm	
		13mm	
		15mm	
		17mm	
		18mm	
		19mm	
		22mm	
		24mm	
		27mm	
		30mm	
		内六角扳手 Wrench, Hex Key	2mm
	3mm		
	4mm		
	5mm		
	6mm		
	7mm		
	8mm		
	9mm		
	10mm		
	11mm		
	12mm		
奶头锤 Hammer, Ball Pein	340g		
	八角锤 Hammer, Sledge		1000g
	削皮刀 Knife, Common		185mm
除锈刀 Scraper, Flat	30"200mm		
	机械冲子 Punch, Machinists'	14"150mm	
顶出冲子 Drift Cylindrical	6"12"115		
	8"14"120		
	10"16"145		
克丝钳 Pliers, Lineman	200mm		
	斜口钳 Pliers, Diagonal Cutting	6"	
	套入式水泵钳 Pliers, Slip Joint	10"	
尖嘴钳 Pliers, Long Nose	6"		
	一字螺丝刀 Slotted Screwdriver	100*4mm	
十字螺丝刀 Phillips Screwdriver	75*4mm		
	100*5mm		
	150*6mm		
	8"200mm		
	100mm		
箱子 Tool Case	125mm		
	200mm		
	300mm		

货号	名称	规格	
铝青铜合金	DESCRIPTION	SPECIFICATION	
AL28-85	镊子 Tweezer, Neat Tips	200mm	
		T型钎子 Marking Tool	187mm
		削皮刀 Knife	193mm
		裁剪刀 Scissors	225mm
		锯弓子 Hacksaw Frame	500mm
		锯条 Hacksaw Blade	300mm
		腻子刀 Knife, Putty	40*200mm
		长柄圆头刷 Brush	4"19
		一字螺丝刀 Slotted Screwdriver	3"50mm
			6"150mm
			6"100mm
		S型螺丝刀 Slotted Offset Screwdriver	8"150mm
			8"200mm
			6"72mm
		十字螺丝刀 Phillips Screwdriver	8"125mm
	10"196mm		
	#1"75		
	鲤鱼钳 Pliers, Adjustable Combination	#2"125	
		#3"200	
		#3"250	
		200mm	
		150mm	
		鸭嘴钳 Pliers, Flat Nose	150mm
			尖嘴钳 Pliers, Long Nose
		斜嘴钳 Pliers, Diagonal Cutting	170mm
			剥线钳 Wire Stripping Pliers
		圆嘴钳 Pliers, Round Nose	200mm
			克丝钳 Pliers, Lineman
		活扳手 Wrench, Adjustable	250mm
			350mm
		美式管钳子 Wrench, Pipe (American Type)	0.68kg
			奶头锤 Hammer, Ball Pein
	英式平顶锤 Club Hammer	16"160	
		圆形扁铲 Chisel, Flat	Φ25*300mm
	撬棍 Bar	Φ15*500mm	
		400mm	
		1/2"245	
		羊角起钉钳 Bar, Wrecking	1/2"
			换向棘轮 Ratchet Wrench
		滑动手柄 Sliding T Handle	1/2"100
			套筒连接杆 Driver Extension
		万向接头 Universal Joint	1/2"
			1/2"方套筒头 Socket (1/2")
		内六角扳手 Wrench, Hex Key	7/16"
			1/2"
9/16"			
5/8"			
11/16"			
3/4"			
13/16"			
7/8"			
15/16"			
1"			
1-1/16"			
1-1/4"			
英制内六角扳手 Wrench, Hex Key	(1.5, 2, 2.5, 3, 4, 5, 6, 8, 10) mm		
	1/16"		
	5/64"		
	3/32"		
	1/8"		
	5/32"		
	3/16"		
	7/32"		
	1/4"		
	5/16"		
	3/8"		
	7/16"		
	箱子 Tool Case		