

# US40 Pipe Beveling Machine

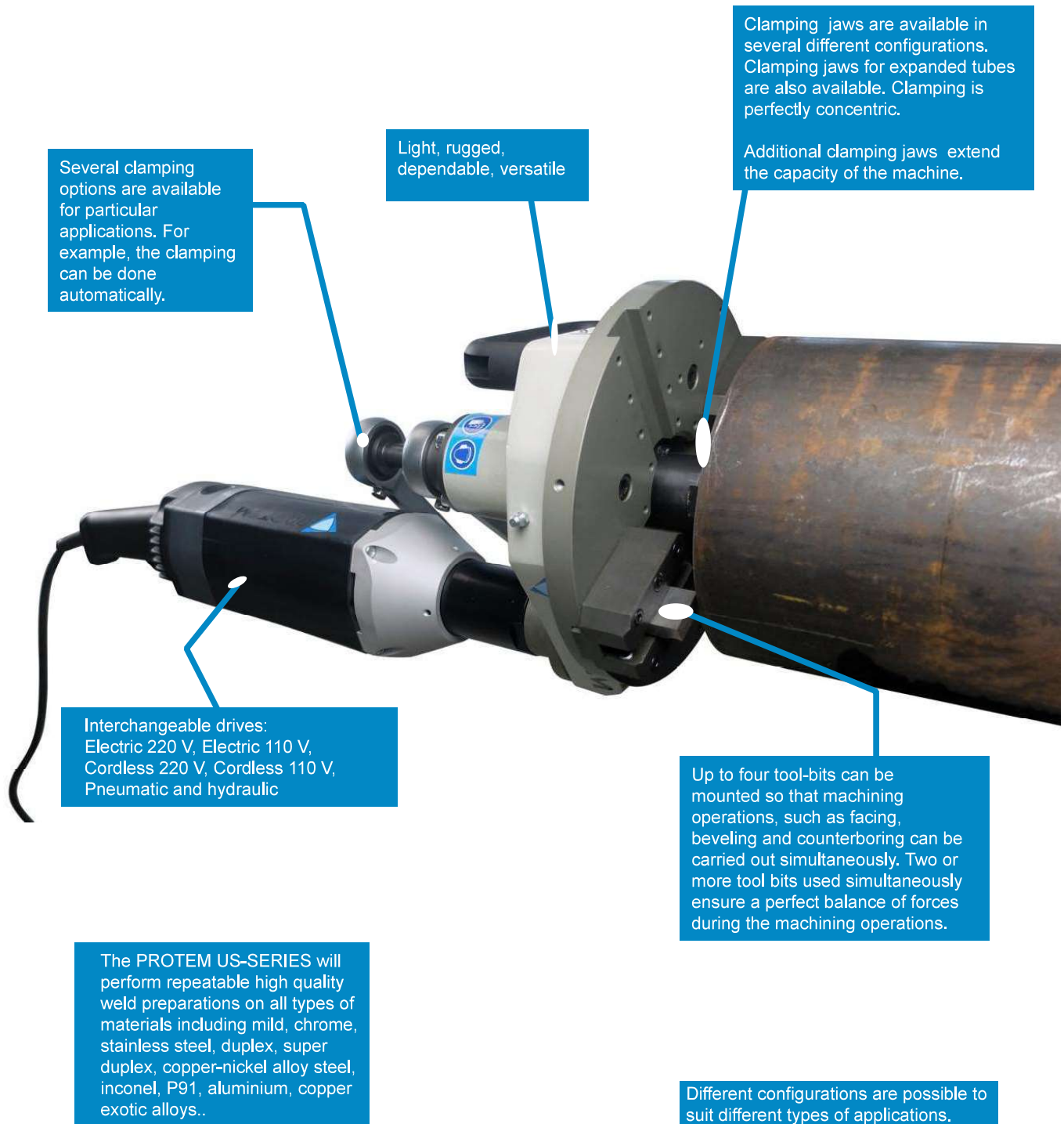

Several clamping options are available for particular applications. For example, the clamping can be done automatically.

Light, rugged, dependable, versatile

Clamping jaws are available in several different configurations. Clamping jaws for expanded tubes are also available. Clamping is perfectly concentric. Additional clamping jaws extend the capacity of the machine.

Interchangeable drives:  
Electric 220 V, Electric 110 V,  
Cordless 220 V, Cordless 110 V,  
Pneumatic and hydraulic

The PROTEM US-SERIES will perform repeatable high quality weld preparations on all types of materials including mild, chrome, stainless steel, duplex, super duplex, copper-nickel alloy steel, inconel, P91, aluminium, copper exotic alloys..

Up to four tool-bits can be mounted so that machining operations, such as facing, beveling and counterboring can be carried out simultaneously. Two or more tool bits used simultaneously ensure a perfect balance of forces during the machining operations.

Different configurations are possible to suit different types of applications.

**ID Mounted**

# US40 Pipe Beveling Machine

Standard Capacity: 43mm - 219mm (1.692" - 8.622")

Extended Capacity: 43mm - 273mm (1.629" - 10.748")



US40 with pneumatic drive

The portable id mount PROTEM US40 tube and pipe beveling machine is powerful, durable, reliable and versatile. The US40 covers  $\varnothing$  ranging from 43mm (1.692") to 219mm (8.622"). The standard tool plate will accept multiple tool-bits, allowing up to four simultaneous machining operations which may include 30°, 37°30', 45° bevels with or without land, J-bevels, compound bevels, facing, counterboring operations, cutting tubes to length and removal of weld joints on boiler panels.

The tool-bits can be changed and adjusted very quickly. Carbide tool inserts may also be used. The US40 features a self-accepting torque system and an integral drive motor. It can be either pneumatically or electrically or hydraulically driven. The PROTEM US40 will perform repeatable high quality weld preparations on all types of materials including mild steel, chrome, stainless steel, duplex, super duplex, copper-nickel alloy steel, inconel, P91, aluminium, copper and exotic alloys.

Beveling	Squaring	Counter-boring	Cut to length	Weld Joint Removal	Coating Removal	Saddles	Surfacing
✓	✓	✓	✓	✓	✓	✗	✓

ID Mounted

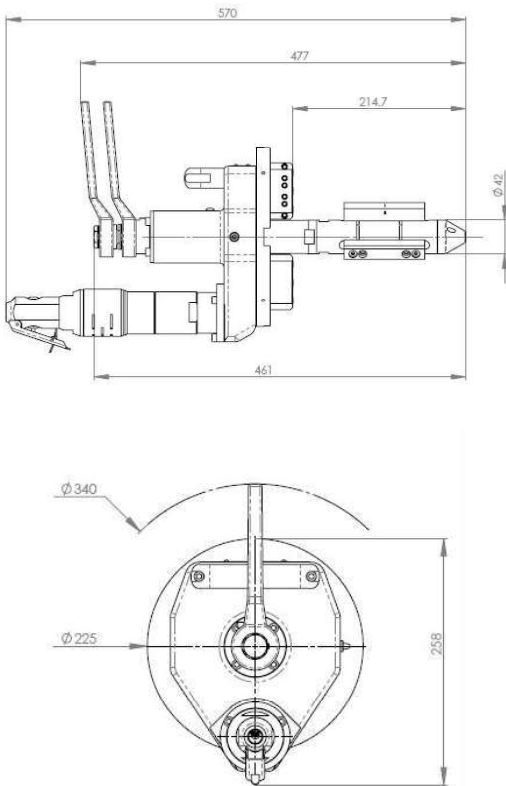

Dimensions

## Advantages:

- Portable
- Powerful Machining Equipment
- Easy and Safe use for the Operators
- No Heat Affected Zone
- High Accuracy
- Fast and easy mounting
- The tool-bits can be changed and adjusted very quickly
- Adapted for works in tight spaces
- The machine can be used in all positions: vertical, horizontal, over head
- Versatile Cutting Head: the tool-holder plate can accept up to 4 tool-bits for simultaneous machining operations (land, bevel, counterboring, j prep)
- Smooth and Burr-Free Surface Finish
- No vibration during the machining process



US40 with electric drive

# US40 Pipe Beveling Machine

## Technical Features:

<b>Specific shapes &amp; angles</b>	Facing 90°, bevel 30°, 37°30, 45°, counterbore, J-bevel, Other on request
<b>Clamping</b>	Manual with a key
<b>Feed stroke</b>	50 mm (1.968")
<b>Expansion</b>	15 mm (0.590")
<b>Cutting head gear drive</b>	25 rpm off-load speed 16 rpm nominal speed. Approximate rotation speed according to air pressure and air flow
<b>Pneumatic drive</b>	730 W, 6 bar (87 psi), 1400 l/min (49 cfm)
<b>Electric drive</b>	110 V (1500 W) or 220 V (1050 W)
Pneumatically driven machines have to be used with a lubricating filter. Recommended option: regulation valve.	

Order No.	Description
US40-1000	Pipe Facing Machine PROTEM US40 with pneumatic drive, for Ø 1.692" - 8.622" (43mm - 219mm)
US40-1020	Pipe Facing Machine PROTEM US40 with electric drive 220V, for Ø 1.692" - 8.622" (43mm - 219mm)
US40-1022	Pipe Facing Machine PROTEM US40 with electric drive 220V MS15. for Ø 1.692" - 8.622" (43mm - 219mm)
US40-1040	Pipe Facing Machine PROTEM US40 with electric drive 110V, for Ø 1.692" - 8.622" (43mm - 219mm)
US40-1060	Pipe Facing Machine PROTEM US40 with single hydraulic drive and regulation valve, for Ø 1.692" - 8.622" (43mm - 219mm)
US40-1062	Pipe Facing Machine PROTEM US40 with single hydraulic drive, for Ø 1.692" - 8.622" (43mm - 219mm)

## Applications:

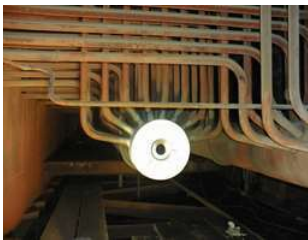

ID Mounted

## Use On-Site or in Workshop:

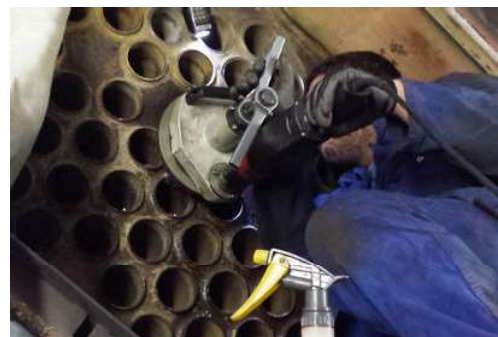

# US40CA Beveling Machine with automatic clamping System

Standard Capacity: 43mm - 219mm (1.692" - 8.622")

Extended Capacity: 43mm - 273mm (1.629" - 10.748")

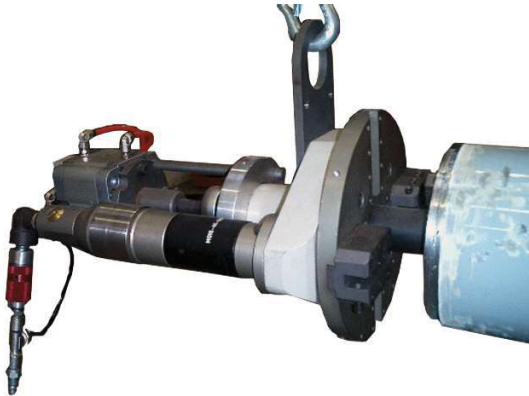

The portable id mount PROTEM US40CA tube and pipe beveling machine is powerful, durable, reliable and versatile. The US40CA covers  $\varnothing$  ranging from 43mm (1.692") to 219mm (8.622"). The standard tool plate will accept multiple tool-bits, allowing up to four simultaneous machining operations which may include 30°, 37°30, 45° bevels with or without land, J-bevels, compound bevels, facing, counterboring operations, cutting tubes to length and removal of weld joints from heat exchanger tubes.

The tool-bits can be changed and adjusted very quickly. Carbide tool inserts may also be used. The US40CA features a self-accepting torque system and an integral drive motor. It can be either pneumatically or electrically or hydraulically driven. The PROTEM US40CA will perform repeatable high quality weld preparations on all types of materials including mild steel, chrome, stainless steel, duplex, super duplex, copper-nickel alloy steel, inconel, P91, aluminium, copper and exotic alloys.

Beveling	Squaring	Counter-boring	Cut to length	Weld Joint Removal	Coating Removal	Saddles	Surfacing
✓	✓	✓	✓	✓	✗	✗	✗

ID Mounted

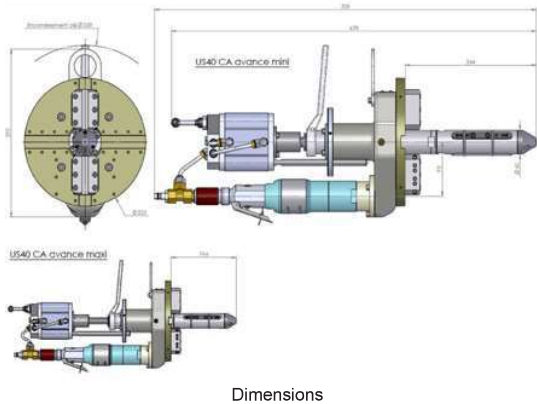

## Technical Features:

<b>Specific shapes &amp; angles</b>	Facing 90°, bevel 30°, 37°30, 45°, counterbore, J-bevel, Other on request
<b>Clamping</b>	Automatic
<b>Feed stroke</b>	50 mm (1.968")
<b>Cutting head gear drive</b>	25 rpm off-load speed 16 rpm nominal speed. Approximate rotation speed according to air pressure and air flow
<b>Pneumatic drive</b>	730 W, 6 bar (87 psi), 1400 l/min (49 cfm)
Pneumatically driven machines have to be used with a lubricating filter. Recommended option: regulation valve.	

Order No.	Description
US40CA-1000	Pipe Facing Machine PROTEM US40 with single pneumatic drive, for $\varnothing$ 1.692" - 8.622" (43mm - 219mm). The US40CA features an integrated automatic clamping system.

## US40CA On-Site:

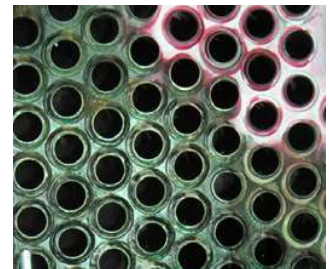

## US40 Crates:

Order No.	Description
US40-K01	Transport crate for US40 pneumatic
US40-K02	Transport crate for US40 with right angled drive
US40-K03	Transport crate for US40 hydraulic
US40-K05	Transport crate for US40E (MS10-MS15)
US40-K06	Transport crate for US40 pneumatic + bench
US40-K07	Transport box for US40-EMA-NG
US40-K10	Transport crate for US40 copying carriage
US40-K11	Transport crate for US40-ASB
US40-K12	Transport crate for US40E MS15 + RA
US40CA-K01	Transport crate for US40CA pneumatic

## US40 Elbow Mandrels:

Order No.	Description
US40PR/C-1000	Spider type elbow mandrel kit: This new generation of elbow mandrel assembly allows the positioning of an ID Mount Beveling Machine on all types of elbows.
US40PR/C-1001	Elbow mandrel assembly EMA for US40 for $\varnothing$ 3.346" - 7.086" (85mm - 180mm)
US40PR/C-1002	Elbow mandrel assembly EMA for US40 for $\varnothing$ 5.708" - 8.622" (145mm - 219mm)

## US40 Further Options:















Order No.	Description
US40-1115	Additional tool-holder
US40-2400	Bench mounting device for US40
US40-2500	ID Tracker for US40 for $\varnothing$ 4.724" - 8.622" (120mm - 219mm)
US40-3000	Copying carriage for US40 Stroke 2.559" (65mm)
US40-3100	Flange facing attachment, for flange diameters ranging from 70mm - 400mm (2.756" - 15.748")
US40-3800	Tool-holder for diameter up to 273 mm (10.748")

# US40 Pipe Beveling Machine

# Tool-Bits

ID Mounted

Order No.	Description	Picture
O-US-PP30-9-14026	Insert-holder 30° for US40	
O-US-PP375-9-14007	Insert-holder 37,5° for US40	
O-US-PP45-9-14008	Insert-holder 45° for US40	
O-US-PP90-9-11066	Insert-holder 90° for US40	
O-VIS-V5	Screw for tool insert P2	
O-US-P1-6-H-T	Tool-insert for US25-TIH-30, US30CH-TIH-30 and US40-TIH-30	
O-US-P2-6-H-T	Tool-insert for US25-TIH-90, US30CH-TIH-90 and US40-TIH-90	
O-US-P1-DU-PLEX-30	Tool-insert for US25-TIH-30, US30CH-TIH-30 and US40-TIH-30	
O-US-P2-DU-PLEX-0	Tool-insert for US25-TIH-90, US30CH-TIH-90 and US40-TIH-90	

Order No.	Description	Picture
O-US-A1-9-H-27	Tool-bit 90°	
O-US-A2-9-H-26	Tool-bit for 30° bevel	
O-US-A3-9-H-28	Tool-bit for 37°30 bevel	
O-US-A4-9-H-25	Tool-bit for counterboring 15°	
O-US-A5-9-H-85	Tool-bit for 45° bevel	
O-US-B6-9-H-54	Tool-bit 90°, with disalignment	
O-US-B7-9-H-56	Tool-bit 30°, with disalignment	
O-US-B8-9-H-59	Tool-bit 37°30, with disalignment	
O-US-B9-9-H-61	Tool-bit for counterboring 15°, with disalignment	
O-US-B11-9-H-15	Tool-bit for counterboring and squaring	
O-US-C5-9-H-63	Tool-bit for 7° R6 j-bevels	
O-US-C6-9-H-65	Tool-bit for 12,5° R6 j-bevels	
O-US-C7-9-H-67	Tool-bit for 7° R6 j-bevels, with disalignment	
O-US-C8-9-H-69	Tool-bit for 12,5° R6 j-bevels, with disalignment	
O-US-C9-9-H-29	Tool-bit for 10° R1,5 j-bevels	
O-US-C10-9-H-70	Tool-bit for 20° j-bevels	