

## 5 LEG GIANT JACK

The B&B 5 leg giant jack is ideal for large diameter pipes (up to 36" / 920 mm) and its V-head can be equipped with multiple options.

The 5 leg giant jack can be fitted with caster wheels, allowing pipe movement.

The 5 leg giant jack is characterised by its increased steel dimensions throughout, including 1 3/4" solid ACME rod, making it the toughest on the market.

### Specifications

- Urethane over steel casters with solid hub increase safety and durability.
- 5,000 lbs. capacity without wheels and casters.
- 2,500 lbs. capacity with steel wheels and urethane casters.
- Operating height with swivel casters: 32" - 44" / 82 - 112 cm
- Operating height with jack only: 24" - 36" / 61 - 92 cm
- Minimum - maximum pipe diameter 1" - 36"
- Solid 1 3/4" ACME-thread adjustment.
- 1 1/2" wide steel / phenolic wheels to reduce instances of "pipe travel".
- Can be purchased as a complete kit as shown: jack, casters, and wheels.
- Turning wheels available in steel, stainless steel, and phenolic.
- Multiple add-ons available, including stainless steel sleeves for contamination free fit-up, recommended hold down chain device for transport, ball transfer attachments for variation of pipe movement and more.

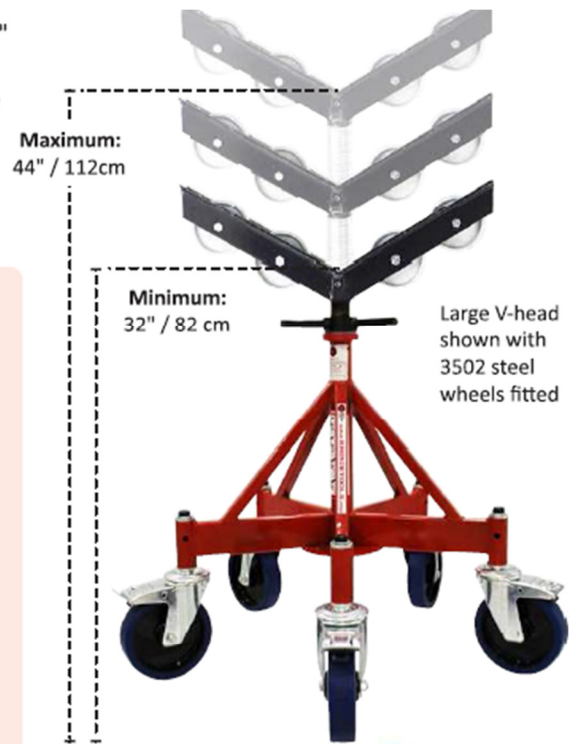

Transport pipes around the site or workshop with ease.



Shown with 3504 caster wheel kit fitted and 3506 hold down chain device



Levelling pads supplied as standard



Hold down chain device 3506 locks pipe to jack

